

Best in the World

REFRIGERATOR MANUFACTURER
Turbo air



www.turboairchina.com



Each of our products certifications may differ under certain specifications and various options.

INDEX



BAKERY CASE 10



BAKERY CASE 19



ROUND BAKERY CASE 20



BAKERY CASE HIGH 22



COMBI SHOW CASE 24



SANDWICH CASE 26



CHOCOLATE CASE 31



OPEN CASE HIGH 33



OPEN ROUND CASE 35



GELATO SHOW CASE 37



GELATO SHOW CASE 37



ICE CREAM DIPPING CABINET 37



CONVECTION OVEN 39



DECK OVER 40



TOP MOUNT K-Series 44



GLASS DOOR K-Series 52



TOP MOUNT Pro-Series 53



TOP MOUNT M3-Series 56



UNDER COUNTER K-Series 59



GLASS DOOR K-Series 64



65

DRAWER
K-Series



67

UNDER COUNTER
M3-Series



69

UNDER COUNTER
Low Boy



71

SALAD PREP TABLE
BUFFET
K-Series



72

SALAD PREP TABLE
HOOD LID
K-Series



74

SALAD PREP TABLE
HOOD LID
M3-Series



75

PIZZA TABLE



76

CHEF BASE



顾客至上

Customer
Always
Comes
First



品质第一

Exceptional
Quality



研发极致

Continuous
R&D
improvements



送货及时

Expedited
Delivery



- | | |
|---------|--|
| 2005.06 | 特博尔公司在中国成立
Founded Turbo air China |
| 2005.10 | 获得UL,ETL,NSF认证
Approved UL,ETL,NSF |
| 2006.02 | 产品开始出口美国
Started Exporting to USA market |
| 2009.06 | 获得CCC,CE,RoHS认证
Approved CCC,CE,RoHS |
| 2009.10 | 正式开始国内销售
Started to sell the domestic market |
| 2010.01 | 开发出K系列大众型25种产品
Launched K-series top mount reach-in(25 models) |
| 2014.07 | 开发出蛋糕柜(18models)
Launched Bakery case(18models) |
| 2015.06 | 开发出Gelato Show case(3种产品)
Launched Gelato show case(3models) |
| 2015.10 | 开发出High bakery case/High open case(8种产品)
Launched High bakery case/High open case(8 models) |
| 2016.08 | TURBO AIR 青岛新工厂成立
Founded Turbo air new Qingdao factory |
| 2017.04 | 美国节能产品开发成功并出口 |
| 2018.10 | 欧洲节能产品获得CE、EEI、ROHS等认证 |

Global Turbo Air Group

Manufacturing Divisions



Selling to 67 Countries

www.turboairinc.com

Branch / Distribution Locations

Immediate Delivery of Your Profit



CALIFORNIA Headquarters

4184 E. Conant St., Long Beach, CA 90808
Tel : 310-900-1000 / Fax : 310-900-1077
Toll Free : 800-627-0032 / Warranty Service : 800-381-7770
www.turboairinc.com



HAWAII



179 Sand Island Access Rd. #B, Honolulu, HI 96819
Tel : 808-843-1988 Fax : 808-843-1991

OAKLAND



1617 Whipple Rd. Suite A, Hayward, CA 94544
Tel : 510-382-0983 Fax : 510-475-5692

SEATTLE



2515 142nd Ave E. Sumner, WA 98390
Tel. 253-518-0380 Fax. 253-826-3162

DENVER



3650 Fraser St. Unit C, Aurora, CO 80011
Tel : 720-459-5887 Fax : 720-459-5886

HOUSTON



4300 N. Sam Houston Pkwy W. #410, Houston, TX 77086
Tel : 281-880-4946 Fax : 281-730-8081

DALLAS



1800 S. Great Southwest Pkwy., Grand Prairie, TX 75051
Tel : 214-678-9380 Fax : 214-678-9386

CHICAGO



101 E. Crossroads Pkwy. Suite B, Bolingbrook, IL 60440
Tel : 630-439-0015 Fax : 630-439-0017

CINCINNATI



12080 Best Place, Sharonville, OH 45241
Tel : 513-772-5272 Fax : 513-772-5276

ATLANTA



5345 Buford Highway, Norcross, GA 30071
Tel : 770-449-1112 Fax : 770-248-9525

NEW JERSEY



10 Basin Dr. Suite 110, S.Kearny, NJ 07032
Tel : 973-274-1993 Fax : 973-274-1990

PITTSBURGH



201 Locust St. Suite B2, Youngwood, PA 15697
Tel : 412-777-9653 Fax : 724-635-0023

MIAMI



2701 SW 145th Ave. Suite 220, Miramar, FL 33027
Tel : 305-885-5722 Fax : 305-885-5723



BAKERY CASE - RECTANGLE 直角型蛋糕展示柜

风循环系统

前入后出，均匀出风，增加内部温度的一致性



LED灯

高亮度、环保、节能LED,让食物展示更加清晰，艳丽。



数字温控系统

进口显示板、温控器。精准控制温度、电源、灯光等。实现食物的持久保鲜和产品的合理使用。



暖风系统

侧面风机，适量暖风。防止侧面玻璃恶劣环境中结露



高级钢化玻璃

采用高级钢化玻璃，保证用户使用安全。透明度高，360°无死角展示。



温度显示

便于快速准确观察柜内温度，及时调节，保持食品新鲜。



化霜水满报警系统

专利设计，化霜水满，温控板自动报警，防止化霜水溢出。使用安心。



颜色选择

可选不锈钢、镜面、大理石的不同色泽。

CHOCOLATE CASE 巧克力展示柜

高级钢化玻璃

采用高级钢化玻璃，保证用户使用安全。透明度高，360°无死角展示。



LED底板灯

增加亮度柜内亮度，提升食物色彩。



小型LED照明

增加亮度柜内亮度，提升食物色彩。



数字温控系统

进口显示板、温控器。精准控制温度、电源、灯光等。实现食物的持久保鲜和产品的合理使用。



背面冷藏空间

增大产品容积，提高产品利用率。



温度显示

便于快速准确观察柜内温度，及时调节，保持食品新鲜。



化霜水满报警系统

专利设计，化霜水满，温控板自动报警，防止化霜水溢出。使用安心。



颜色选择

可选大理石的不同色泽。



OPEN CASE 风幕柜

LED广告灯
亮化广告，突出产品特色。



高级钢化玻璃
采用高级钢化玻璃，保证用户使用安全。透明度强，360°无死角展示。



触摸温控系统
显示板均进口产品，可控制电源，温度，灯光，精密调节温度持久保持食品新鲜度。



蜂窝导流板
保证产品冷气的平均分布，达到产品内部温度均匀保证内部最佳的冷藏温度。



LED灯
高亮度、环保、节能LED,让食物展示更加清晰，艳丽。



风幕帘
减少冷气流失，产品的食物能在最佳储存环境存放。



风循环系统
前入后出，均匀出风，增加内部温度的一致性。



简单设计
便于维修和保养。

COMBI SHOW CASE 双温蛋糕饮料柜

风循环系统
前入后出，均匀出风，增加内部温度的一致性



LED灯
高亮度、环保、节能LED,让食物展示更加清晰，艳丽。



数字温控系统
进口显示板、温控器。精准控制温度、电源、灯光等。实现食物的持久保鲜和产品的合理使用。



空气高效流通
空气高效流通，保证机器寿命



高级钢化玻璃
采用高级钢化玻璃，保证用户使用安全。透明度强，360°无死角展示。



温度显示
便于快速准确观察柜内温度，及时调节，保持食品新鲜。



化霜水满报警系统
专利设计，化霜水满，温控板自动报警，防止化霜水溢出。使用安心。



颜色选择
可选不锈钢、镜面、大理石的不同色泽。

BAKERY CASE

直角型蛋糕柜

RECTANGLE BAKERY CASE

弧型蛋糕柜

ROUND BAKERY CASE



直角型蛋糕柜 RECTANGLE BAKERY CASE

TBP900-1



TBP900-2



TBP900-3

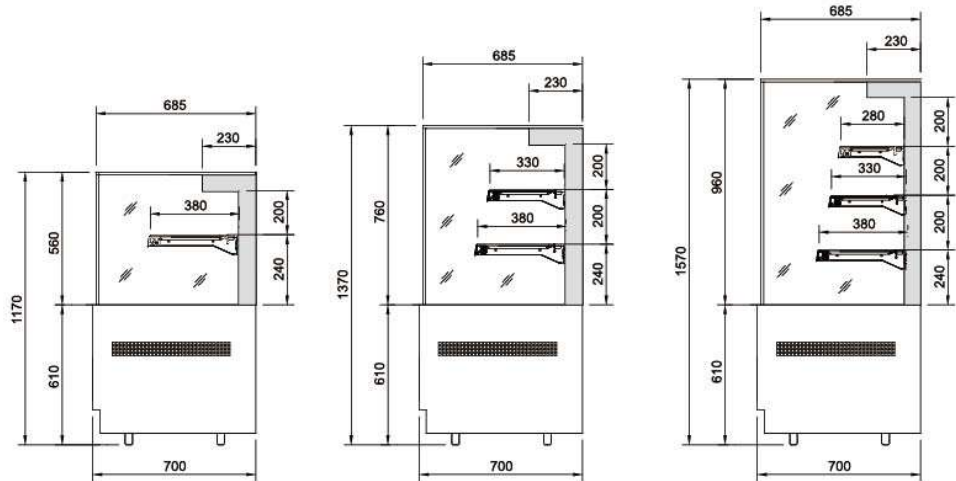
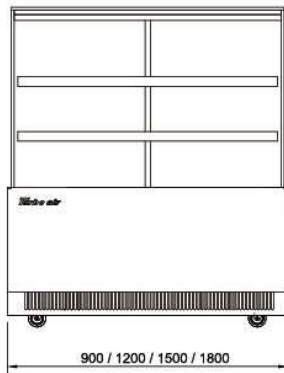

型号/Model	TBP900-1	TBP900-2	TBP900-3
分类/Classification	冷藏 (Refrigerator)		
外观尺寸/Cabinet Dimensions (W*D*H,mm)	900 x 700 x 1170	900 x 700 x 1370	900 x 700 x 1570
容量/Capacity (Liters)	255	355	455
柜内温度/Inner Temperature (°C)	3 °C ~ 8 °C		
开门方式/Door Type	Sliding Door		
搁物架数量/# of shelves	1 (2Layer)	2 (3Layer)	3 (4Layer)
制冷剂/frigerant	R-404A		
压缩机/Comperssor(HP)	3 / 4		
制冷方式/Cooling Type	风冷/Fan cooling type		
隔热方式/Isullation Type	整体高密度发泡 (Polyurethane) / 环戊烷 (Cyclopentane) / 不含氯氟烃 (CFC Free)		
温度控制类型/Temperature control type	数字温控/Digital		
电流/Amps (A)	3.5	3.8	4.4
电源/Voltage(V/Hz/Ph)	220V / 50 / 1		
功率/Power(W)	620	670	830
重量/Weight (Kg)	175	180	185

TBP1200-1



TBP1200-2



TBP1200-3

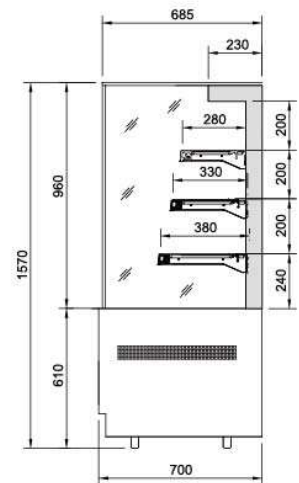
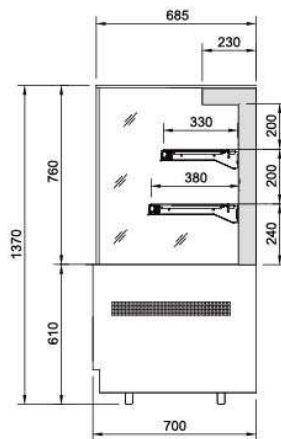
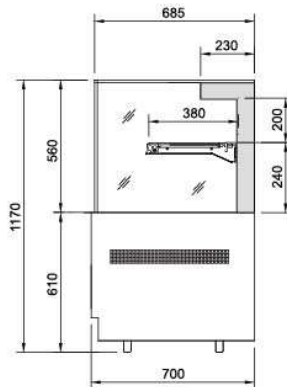
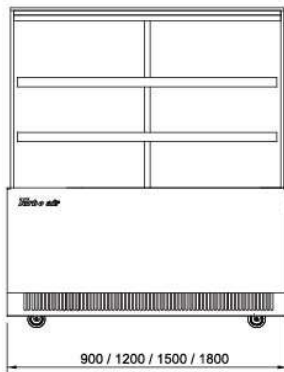

型号/Model	TBP1200-1	TBP1200-2	TBP1200-3
分类/Classification	冷藏 (Refrigerator)		
外观尺寸/Cabinet Dimensions (W*D*H,mm)	1200 x 700 x 1170	1200 x 700 x 1370	1200 x 700 x 1570
容量/Capacity (Liters)	345	485	620
柜内温度/Inner Temperature (°C)	3 °C ~ 8 °C		
开门方式/Door Type	Sliding Door		
搁物架数量/# of shelves	1 (2Layer)	2 (3Layer)	3 (4Layer)
制冷剂/frigerant	R-404A		
压缩机/Comperssor(HP)	3 / 4		
制冷方式/Cooling Type	风冷/Fan cooling type		
隔热方式/Isullation Type	整体高密度发泡 (Polyurethane) / 环戊烷 (Cyclopentane) / 不含氯氟烃 (CFC Free)		
温度控制类型/Temperature control type	数字温控/Digital		
电流/Amps (A)	3.8	4.4	4.8
电源/Voltage(V/Hz/Ph)	220V / 50 / 1		
功率/Power(W)	670	830	860
重量/Weight (Kg)	225	230	235

BAKERY CASE

COMBI SHOWCASE

SANDWICH CASE

CHOCOLATE CASE

OPEN CASE

ICE MAKER

CELATO SHOW CASE

BAKING LINE

TBP1500-1



TBP1500-2



TBP1500-3

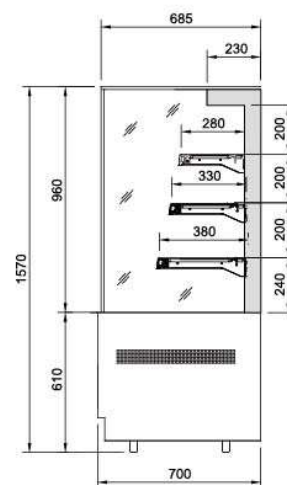
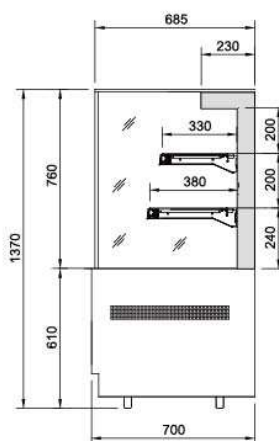
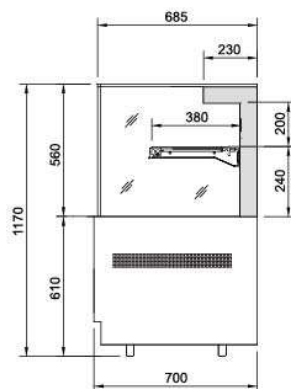
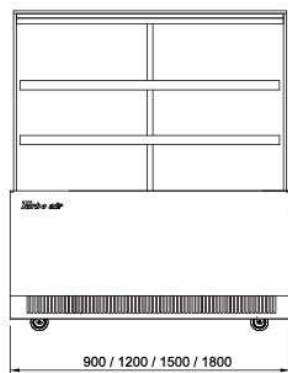

型号/Model	TBP1500-1	TBP1500-2	TBP1500-3
分类/Classification	冷藏 (Refrigerator)		
外观尺寸/Cabinet Dimensions (W*D*H,mm)	1500 x 700 x 1170	1500 x 700 x 1370	1500 x 700 x 1570
容量/Capacity (Liters)	440	615	785
柜内温度/Inner Temperature (°C)	3 °C ~ 8 °C		
开门方式/Door Type	Sliding Door		
搁物架数量/# of shelves	1 (2Layer)	2 (3Layer)	3 (4Layer)
制冷剂/frigerant	R-404A		
压缩机/Comperssor(HP)	3 / 4		
制冷方式/Cooling Type	风冷/Fan cooling type		
隔热方式/Isullation Type	整体高密度发泡 (Polyurethane) / 环戊烷 (Cyclopentane) / 不含氟氯烃 (CFC Free)		
温度控制类型/Temperature control type	数字温控/Digital		
电流/Amps (A)	4.4	4.8	5
电源/Voltage(V/Hz/Ph)	220V / 50 / 1		
功率/Power(W)	830	850	880
重量/Weight (Kg)	265	270	275

TBP1800-1



TBP1800-2



TBP1800-3

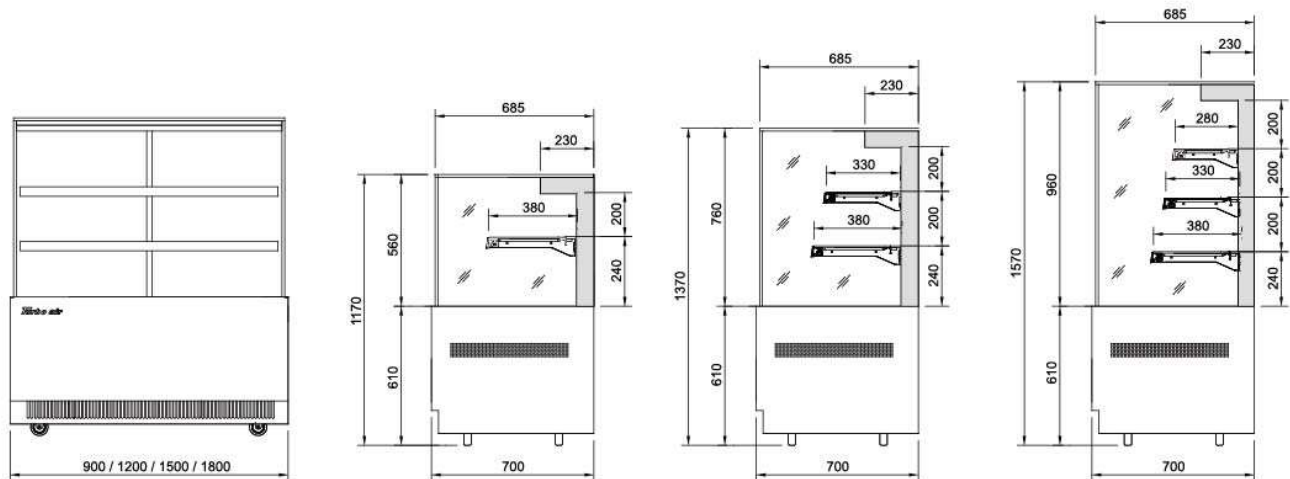

型号/Model	TBP1800-1	TBP1800-2	TBP1800-3
分类/Classification	冷藏 (Refrigerator)		
外观尺寸/Cabinet Dimensions (W*D*H,mm)	1800 x 700 x 1170	1800 x 700 x 1370	1800 x 700 x 1570
容量/Capacity (Liters)	530	740	950
柜内温度/Inner Temperature (°C)	3 °C ~ 8 °C		
开门方式/Door Type	Sliding Door		
搁物架数量/# of shelves	1 (2Layer)	2 (3Layer)	3 (4Layer)
制冷剂/frigerant	R-404A		
压缩机/Comperssor(HP)	3 / 4		
制冷方式/Cooling Type	风冷/Fan cooling type		
隔热方式/Isullation Type	整体高密度发泡 (Polyurethane) / 环戊烷 (Cyclopentane) / 不含氟氯烃 (CFC Free)		
温度控制类型/Temperature control type	数字温控/Digital		
电流/Amps (A)	4.8	5	5.2
电源/Voltage(V/Hz/Ph)	220V / 50 / 1		
功率/Power(W)	850	880	920
重量/Weight (Kg)	280	290	300

BAKERY CASE

TBP2100-1

TBP2100-2

TBP2100-3



COMBI SHOWCASE

SANDWICH CASE

CHOCOLATE CASE

OPEN CASE

ICE MAKER

CELATO SHOW CASE

BAKING LINE

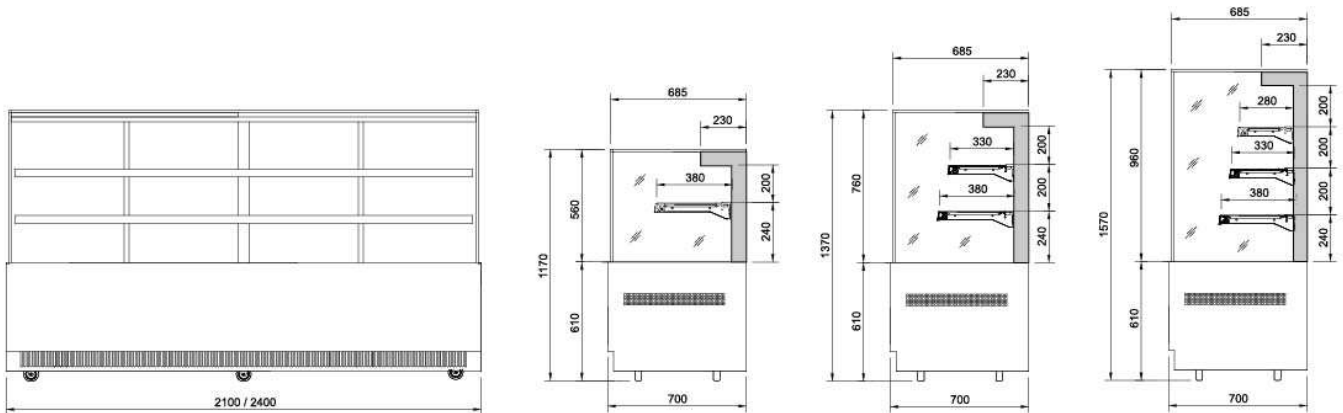

型号/Model	TBP2100-1	TBP2100-2	TBP2100-3
分类/Classification	冷藏 (Refrigerator)		
外观尺寸/Cabinet Dimensions (W*D*H,mm)	2100 x 700 x 1170	2100 x 700 x 1370	2100 x 700 x 1570
容量/Capacity (Liters)	620	870	1115
柜内温度/Inner Temperature (°C)	3 °C ~ 8 °C		
开门方式/Door Type	Sliding Door		
搁物架数量/# of shelves	1 (2Layer)	2 (3Layer)	3 (4Layer)
制冷剂/frigerant	R-404A		
压缩机/Comperssor(HP)	1		
制冷方式/Cooling Type	风冷/Fan cooling type		
隔热方式/Isullation Type	整体高密度发泡 (Polyurethane) / 环戊烷 (Cyclopentane) / 不含氯氟烃 (CFC Free)		
温度控制类型/Temperature control type	数字温控/Digital		
电流/Amps (A)	5	5.2	5.5
电源/Voltage(V/Hz/Ph)	220V / 50 / 1		
功率/Power(W)	880	920	970
重量/Weight (Kg)	300	310	320

TBP2400-1



TBP2400-2



TBP2400-3

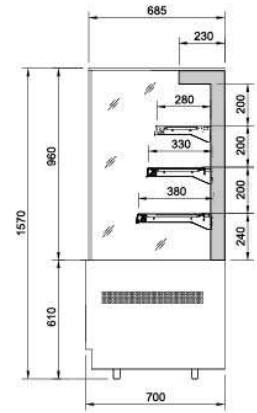
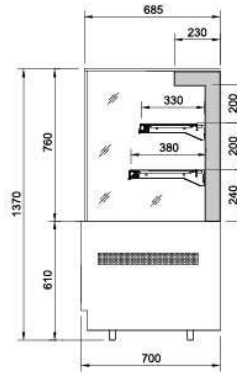
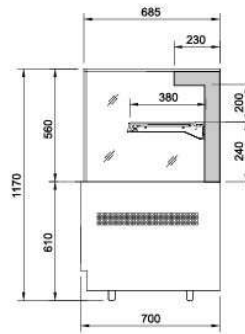
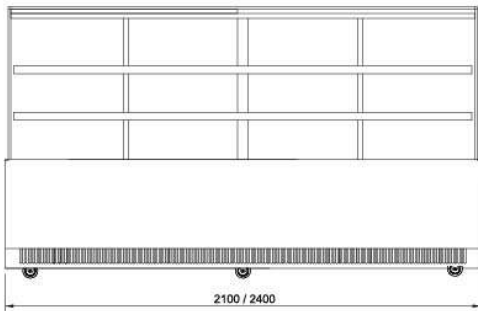

型号/Model	TBP2400-1	TBP2400-2	TBP2400-3
分类/Classification	冷藏 (Refrigerator)		
外观尺寸/Cabinet Dimensions (W*D*H,mm)	2400 x 700 x 1170	2400 x 700 x 1370	2400 x 700 x 1570
容量/Capacity (Liters)	710	1000	1280
柜内温度/Inner Temperature (°C)	3 °C ~ 8 °C		
开门方式/Door Type	Sliding Door		
搁物架数量/# of shelves	1 (2Layer)	2 (3Layer)	3 (4Layer)
制冷剂/frigerant	R-404A		
压缩机/Comperssor(HP)	1		
制冷方式/Cooling Type	风冷/Fan cooling type		
隔热方式/Isullation Type	整体高密度发泡 (Polyurethane) / 环戊烷 (Cyclopentane) / 不含氯氟烃 (CFC Free)		
温度控制类型/Temperature control type	数字温控/Digital		
电流/Amps (A)	5.2	5.5	6
电源/Voltage(V/Hz/Ph)	220V / 50 / 1		
功率/Power(W)	920	970	1060
重量/Weight (Kg)	330	340	350

TBP1200-1L

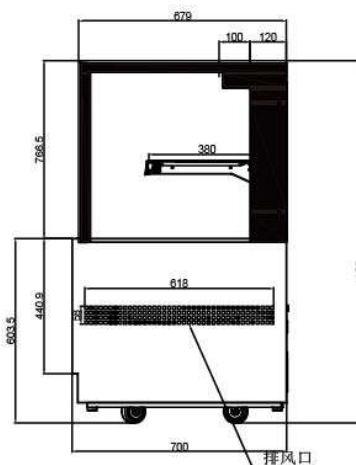
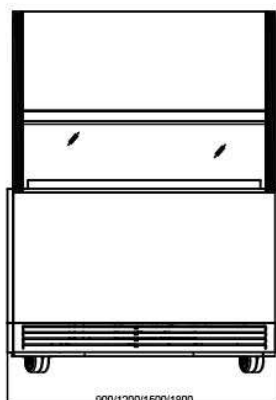

TBP900-1L

TBP1500-1L

TBP1800-1L



型号/Model	TBP900-1L	TBP1200-1L	TBP1500-1L	TBP1800-1L
分类/Classification	冷藏 (Refrigerator)			
外观尺寸/Cabinet Dimensions (W*D*H,mm)	900x700x1186	1200x700x1186	1500x700x1186	1800x700x1186
容量/Capacity (Liters)	255	345	440	530
柜内温度/Inner Temperature (°C)	3 °C ~ 8 °C			
开门方式/Door Type	Sliding Door			
搁物架数量/# of shelves	1 (2Layer)			
制冷剂/frigerant	R-404A			
压缩机/Comperssor(HP)	3/4			
制冷方式/Cooling Type	风冷/Fan cooling type			
隔热方式/Isullation Type	整体高密度发泡 (Polyurethane) / 环戊烷 (Cyclopentane) / 不含氯氟烃 (CFC Free)			
温度控制类型/Temperature control type	数字温控/Digital			
电流/Amps (A)	3.5	3.8	4.4	4.8
电源/Voltage(V/Hz/Ph)	220V / 50 / 1			
功率/Power(W)	620	670	830	850
重量/Weight (Kg)	175	225	265	280

TBP1200-2L

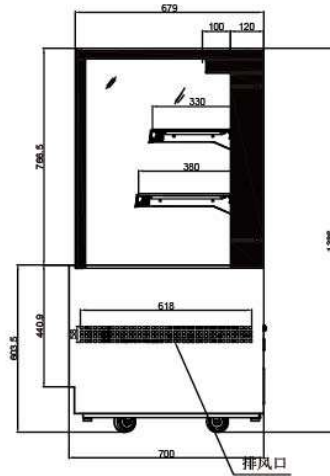
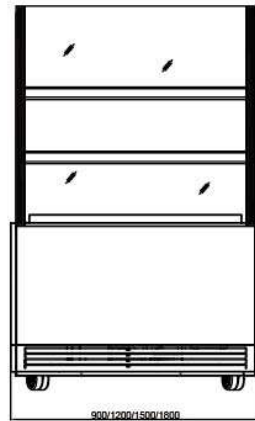

TBP900-2L



TBP1500-2L



TBP1800-2L



型号/Model	TBP900-2L	TBP1200-2L	TBP1500-2L	TBP1800-2L
分类/Classification	冷藏 (Refrigerator)			
外观尺寸/Cabinet Dimensions (W*D*H,mm)	900x700x1386	1200x700x1386	1500x700x1386	1800x700x1386
容量/Capacity (Liters)	335	485	615	740
柜内温度/Inner Temperature (°C)	3 °C ~ 8 °C			
开门方式/Door Type	Sliding Door			
搁物架数量/# of shelves	2(3Layer)			
制冷剂/frigerant	R-404A			
压缩机/Comperssor(HP)	3/4			
制冷方式/Cooling Type	风冷/Fan cooling type			
隔热方式/Isullation Type	整体高密度发泡 (Polyurethane) / 环戊烷 (Cyclopentane) / 不含氯氟烃 (CFC Free)			
温度控制类型/Temperature control type	数字温控/Digital			
电流/Amps (A)	3.8	4.5	4.8	5
电源/Voltage(V/Hz/Ph)	220V / 50 / 1			
功率/Power(W)	670	830	850	880
重量/Weight (Kg)	190	235	275	295

BAKERY CASE

COMBI SHOWCASE

SANDWICH CASE

CHOCOLATE CASE

OPEN CASE

ICE MAKER

CELATO SHOW CASE

BAKING LINE

TBP-1200L

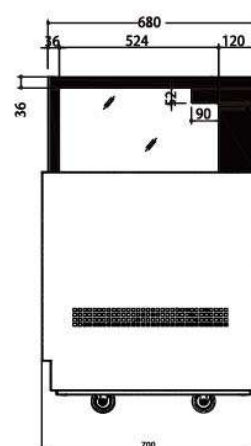
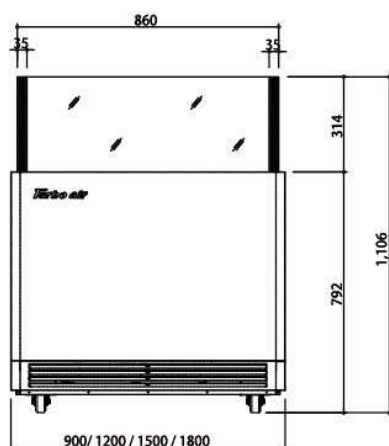

TBP-900L

TBP-1500L

TBP-1800L



型号/Model	TBP-900L	TBP-1200L	TBP-1500L	TBP-1800L
分类/Classification	冷藏 (Refrigerator)			
外观尺寸/Cabinet Dimensions (W*D*H,mm)	900x700x1105	1200x700x1105	1500x700x1105	1800x700x1105
容量/Capacity (Liters)	105	145	182	220
柜内温度/Inner Temperature (°C)	3 °C ~ 8 °C			
开门方式/Door Type	Sliding Door			
搁物架数量/# of shelves	1 Layer			
制冷剂/frigerant	R-404A			
压缩机/Comperssor(HP)	3/4			
制冷方式/Cooling Type	风冷/Fan cooling type			
隔热方式/Isullation Type	整体高密度发泡 (Polyurethane) / 环戊烷 (Cyclopentane) / 不含氯氟烃 (CFC Free)			
温度控制类型/Temperature control type	数字温控/Digital			
电流/Amps (A)	3.5	3.8	4.4	4.8
电源/Voltage(V/Hz/Ph)	220V / 50 / 1			
功率/Power(W)	650	680	830	850
重量/Weight (Kg)	155	205	255	270

弧型蛋糕柜 ROUND BAKERY CASE

TBR1500-2X

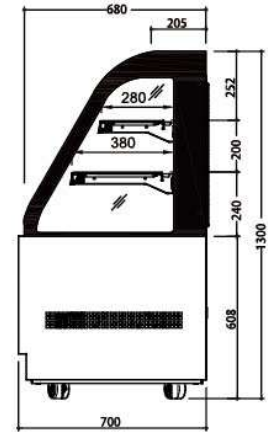
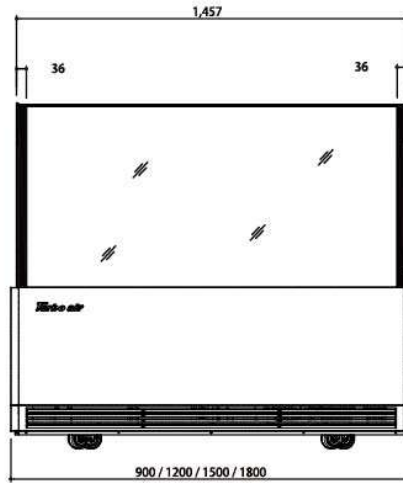

TBR900-2X

TBR1200-2X

TBR1800-2X



型号/Model	TBR900-2X	TBR1200-2X	TBR1500-2X	TBR1800-2X
分类/Classification	冷藏 (Refrigerator)			
外观尺寸/Cabinet Dimensions (W*D*H,mm)	900x700x1300	1200x700x1300	1500x700x1300	1800x700x1300
容量/Capacity (Liters)	335	485	615	740
柜内温度/Inner Temperature (°C)	3 °C ~ 8 °C			
开门方式/Door Type	Sliding Door			
搁物架数量/# of shelves	2(3Layer)			
制冷剂/frigerant	R-404A			
压缩机/Comperssor(HP)	3/4			
制冷方式/Cooling Type	风冷/Fan cooling type			
隔热方式/Isullation Type	整体高密度发泡 (Polyurethane) / 环戊烷 (Cyclopentane) / 不含氯氟烃 (CFC Free)			
温度控制类型/Temperature control type	数字温控/Digital			
电流/Amps (A)	3.8	4.5	4.8	5
电源/Voltage(V/Hz/Ph)	220V / 50 / 1			
功率/Power(W)	670	830	850	880
重量/Weight (Kg)	180	230	270	290

弧型蛋糕柜 ROUND BAKERY CASE

BAKERY CASE

TBR1200-2

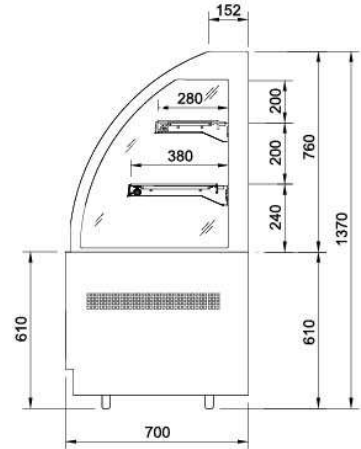
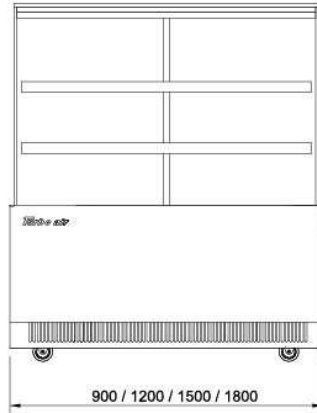

COMBI SHOWCASE

SANDWICH CASE

TBR900-2

TBR1500-2

TBR1800-2



CHOCOLATE CASE

OPEN CASE

ICE MAKER

CELATO SHOW CASE

BAKING LINE

型号/Model	TBR900-2	TBR1200-2	TBR1500-2	TBR1800-2
分类/Classification	冷藏 (Refrigerator)			
外观尺寸/Cabinet Dimensions (W*D*H,mm)	900 x 700 x 1370	1200 x 700 x 1370	1500 x 700 x 1370	1800 x 700 x 1370
容量/Capacity (Liters)	335	485	615	740
柜内温度/Inner Temperature (°C)	3 °C ~ 8 °C			
开门方式/Door Type	Sliding Door			
搁物架数量/# of shelves	2 (3Layer)			
制冷剂/frigerant	R-404A			
压缩机/Comperssor(HP)	3/4			
制冷方式/Cooling Type	风冷/Fan cooling type			
隔热方式/Isullation Type	整体高密度发泡 (Polyurethane) / 环戊烷 (Cyclopentane) / 不含氯氟烃 (CFC Free)			
温度控制类型/Temperature control type	数字温控/D			
电流/Amps (A)	4	4.5	4.5	5
电源/Voltage(V/Hz/Ph)	220V / 50 / 1			
功率/Power(W)	670	830	850	880
重量/Weight (Kg)	180	230	270	290

高型蛋糕柜 BAKERY CASE HIGH

TBH-1200

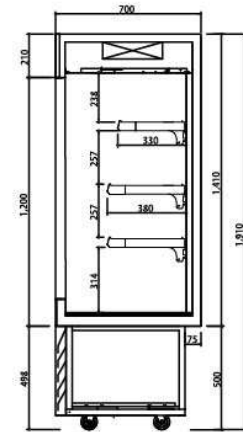
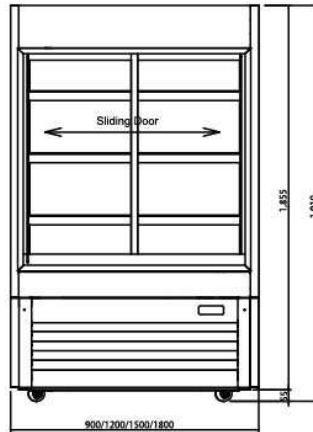

TBH-900



TBH-1500



TBH-1800



型号/Model	TBH-900	TBH-1200	TBH-1500	TBH-1800
分类/Classification	冷藏 (Refrigerator)			
外观尺寸/Cabinet Dimensions (W*D*H,mm)	900 x 700 x 1910	1200 x 700 x 1910	1500 x 700 x 1910	1800 x 700 x 1910
容量/Capacity (Liters)	340	470	600	725
柜内温度/Inner Temperature (°C)	3 °C ~ 8 °C			
开门方式/Door Type	Sliding Door			
搁物架数量/# of shelves	3(4Layer)			
制冷剂/frigerant	R-404A			
压缩机/Comperssor(HP)	1/2			
制冷方式/Cooling Type	风冷/Fan cooling type			
隔热方式/Isullation Type	整体高密度发泡 (Polyurethane)/Cyclopentane(环戊烷) +CFC Free(不含氟氯氢)			
温度控制类型/Temperature control type	数字温控/D			
电流/Amps (A)	4	4.5	4.5	5
电源/Voltage(V/Hz/Ph)	220V / 50 / 1			
功率/Power(W)	800	880	950	1000
重量/Weight (Kg)	200	260	340	380

COMBI SHOWCASE

*He put a
Ring on it!*



双温蛋糕饮料柜 COMBI SHOWCASE

TCB-1500

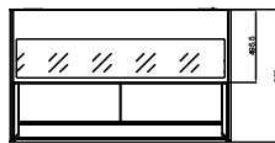

TOP

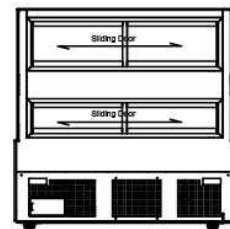

BACK

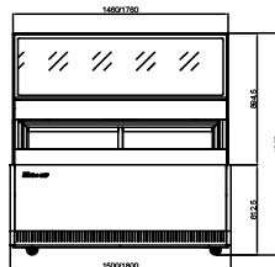

FRONT

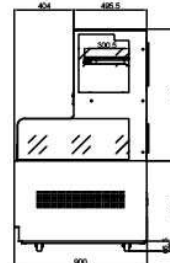

SIDE

TCB-1500



TCB-1800

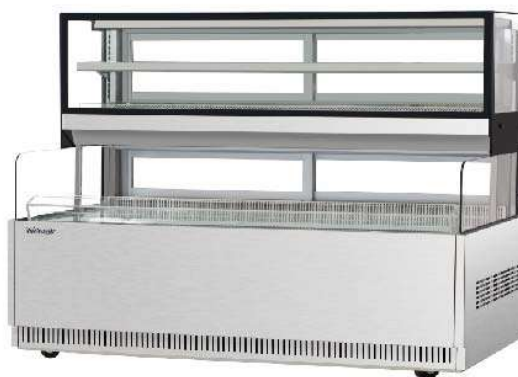

型号/Model	TCB-1500	TCB-1800
分类/Classification	冷藏 (Refrigerator)	
外观尺寸/Cabinet Dimensions (W*D*H,mm)	1500x900x1507	1800x900x1507
容量/Capacity (Liters)	Bakery117/Open256	Bakery142/Open311
柜内温度/Inner Temperature (°C)	Bakery3-8/Open5-10	
开门方式/Door Type	Sliding Door	
搁物架数量/# of shelves	1(2Layer)	
制冷剂/frigerant	R-404A	
压缩机/Comperssor(HP)	1	
制冷方式/Cooling Type	风冷/Fan cooling type	
隔热方式/Isullation Type	整体高密度发泡 (Polyurethane)/Cyclopentane(环戊烷) +CFC Free(不含氟氯氢)	
温度控制类型/Temperature control type	数字温控/D	
电流/Amps (A)	6.7	7.9
电源/Voltage(V/Hz/Ph)	220V / 50 / 1	
功率/Power(W)	1250	1500
重量/Weight (Kg)	300	400

SANDWICCH CASSE



三明治展示柜 SANDWICH CASE

TOS-1200

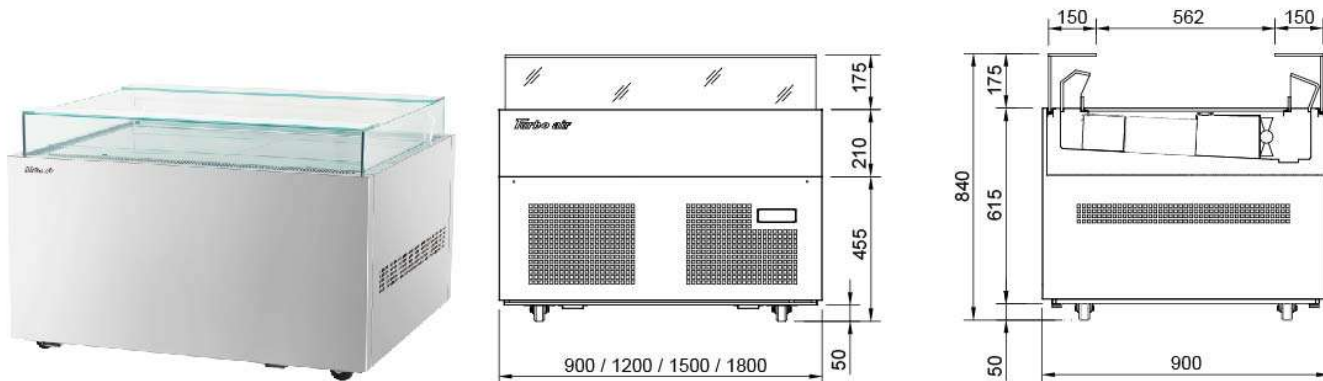

TOS-900

TOS-1500

TOS-1800



型号/Model	TOS-900	TOS-1200	TOS-1500	TOS-1800
分类/Classification	冷藏 (Refrigerator)			
外观尺寸/Cabinet Dimensions(W*D*H,mm)	900 x 900 x 840	1200 x 900 x 840	1500 x 900 x 840	1800 x 900 x 840
容量/Capacity (Liters)	110	150	180	200
柜内温度/Inner Temperature (°C)	5 °C ~ 10 °C			
制冷剂/frigerant	R-404A			
压缩机/Comperssor(HP)	3/4			
制冷方式/Cooling Type	风冷/Fan cooling type			
隔热方式/Isullation Type	整体高密度发泡 (Polyurethane) / 环戊烷 (Cyclopentane) / 不含氟氯烃 (CFC Free)			
温度控制类型/Temperature control type	数字温控/Digital			
电流/Amps (A)	2	2.5	3	3.5
电源/Voltage(V/Hz/Ph)	220V / 50 / 1			
功率/Power(W)	400	500	600	705
重量/Weight (Kg)	140	170	200	230

BAKERY CASE

COMBI SHOWCASE

SANDWICH CASE

CHOCOLATE CASE

OPEN CASE

ICE MAKER

CELATO SHOW CASE

BAKING LINE

TOS-1200P

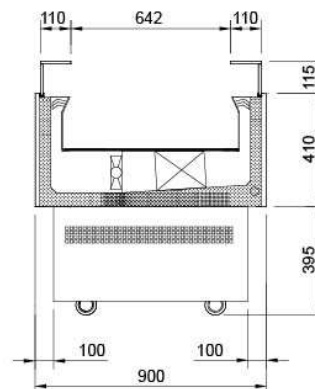
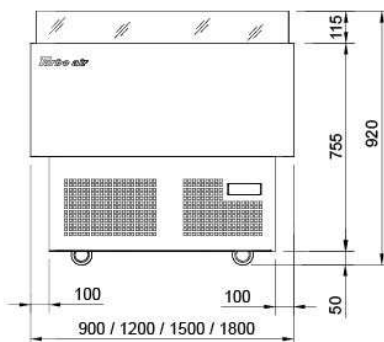

TOS-900P

TOS-1500P

TOS-1800P



型号/Model	TOS-900P	TOS-1200P	TO-S1500P	TOS-1800P
分类/Classification	冷藏 (Refrigerator)			
外观尺寸/Cabinet Dimensions(W*D*H,mm)	900 x 900 x 920	1200 x 900 x 920	1500 x 900 x 920	1800 x 900 x 920
容量/Capacity (Liters)	164	226	289	352
柜内温度/Inner Temperature (°C)	5 °C ~ 10 °C			
制冷剂/frigerant	R-404A			
压缩机/Comperssor(HP)	3/4			
制冷方式/Cooling Type	风冷/Fan cooling type			
隔热方式/Isullation Type	整体高密度发泡 (Polyurethane) / 环戊烷 (Cyclopentane) / 不含氯氟烃 (CFC Free)			
温度控制类型/Temperature control type	数字温控/D			
电流/Amps (A)	2	2.5	3	3.5
电源/Voltage(V/Hz/Ph)	220V / 50 / 1			
功率/Power(W)	400	500	600	705
重量/Weight (Kg)	140	170	200	230

TOS-900C

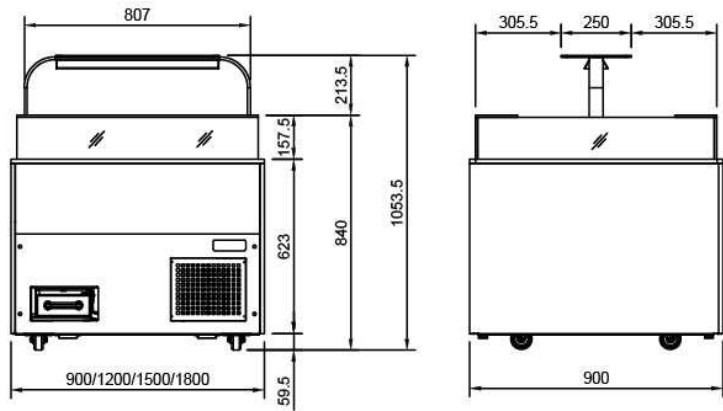

TOS-1200C

TOS-1500C

TOS-1800C



型号/Model	TOS-900C	TOS-1200C	TOS-1500C	TOS-1800C
分类/Classification	冷藏 (Refrigerator)			
外观尺寸/Cabinet Dimensions(W*D*H,mm)	900 x 900 x 1053.5	1200 x 900 x 1053.5	1500 x 900 x 1053.5	1800 x 900 x 1053.5
容量/Capacity (Liters)	110	150	180	200
柜内温度/Inner Temperature (°C)	5 °C ~ 10 °C			
制冷剂/frigerant	R-404A			
压缩机/Comperssor(HP)	3/4			
制冷方式/Cooling Type	风冷/Fan cooling type			
隔热方式/Isullation Type	整体高密度发泡 (Polyurethane) / 环戊烷 (Cyclopentane) / 不含氟氯烃 (CFC Free)			
温度控制类型/Temperature control type	数字温控/Digital			
电流/Amps (A)	2	2.5	3	3.5
电源/Voltage(V/Hz/Ph)	220V / 50 / 1			
功率/Power(W)	400	500	600	705
重量/Weight (Kg)	140	170	200	230



不锈钢 & 彩色钢板 Stainless steel & PCM



原色不锈钢 Stainless (SUS)



黑色 Black



白色 White

大理石 Marble



棕色条纹
Brown Marble



黄色条纹
Yellow Marble



黑色条纹
Black Marble



青黄条纹
Blue & Yellow Marble



黑白条纹
Black & White Marble



白色条纹
White Marble

开门方式 Door type

后开门 Back door



前开门 Front door



Chocolate Case

TCD-900

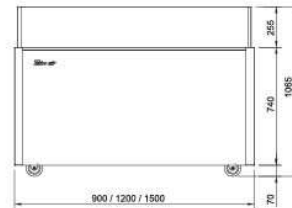
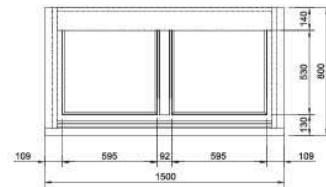

FRONT VIEW

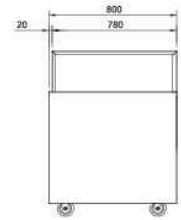

SIDE VIEW

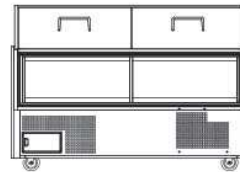

BACK VIEW



巧克力展示柜 Chocolate Case

BAKERY CASE

COMBI SHOWCASE

SANDWICH CASE

CHOCOLATE CASE

OPEN CASE

ICE MAKER

CELATO SHOW CASE

BAKING LINE

TCD-1200



TCD-1500



型号/Model	TCD-900	TCD-1200	TCD-1500	TCD-1800
分类/Classification	冷藏 (Refrigerator)			
外观尺寸/Cabinet Dimensions (W*D*H,mm)	900 x 800 x 1050	1200 x 800 x 1050	1500 x 800 x 1050	1800x800x1050
容量/Capacity (Liters)	211	288	345	410
柜内温度/Inner Temperature (°C)	储藏室 : 5 ~ 8° / 展示柜 : 10 ~ 14° (湿度:50±5%)			
开门方式 Door Type	抽屉 / # of Drawer Door	2		
	推拉门 / # of Sliding door	2		
制冷剂/frigerant	R-404A			
压缩机/Comperssor(HP)	3 / 4	3 / 4	1	1
制冷方式/Cooling Type	风冷/Fan cooling type			
隔热方式/Isullation Type	整体高密度发泡 (Polyurethane) / 环戊烷 (Cyclopentane) / 不含氯氟烃 (CFC Free)			
温度控制类型/Temperature control type	数字温控/Digital			
电流/Amps (A)	4.5	5.1	5.5	6.1
电源/Voltage(V/Hz/Ph)	220V / 50 / 1			
功率/Power(W)	800	900	970	1080
重量/Weight (Kg)	200	225	250	300

OPEN CASE



高型风幕柜 OPEN CASE HIGH

BAKERY CASE

COMBI SHOWCASE

SANDWICH CASE

CHOCOLATE CASE

OPEN CASE

ICE MAKER

CELATO SHOW CASE

BAKING LINE

TOH-1200

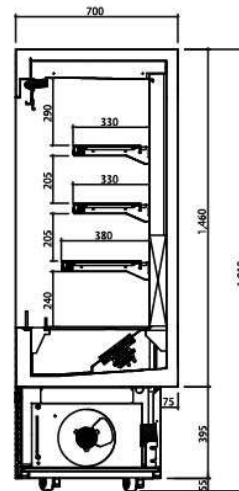
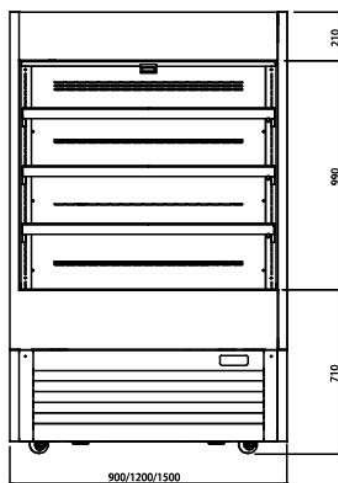

TOH-900



TOH-1500



型号/Model	TOH-900	TOH-1200	TOH-1500
分类/Classification		冷藏 (Refrigerator)	
外观尺寸/Cabinet Dimensions(W*D*H,mm)	900x700x1910	1200x700x1910	1500x700x1910
容量/Capacity (Liters)	340	470	600
柜内温度/Inner Temperature (°C)	5 °C ~ 10 °C		
搁物架数量/# of shelves	3(4Layer)		
制冷剂/frigerant	R-404A		
压缩机/Comperssor(HP)	1/2		
制冷方式/Cooling Type	风冷/Fan cooling type		
隔热方式/Isullation Type	整体高密度发泡 (Polyurethane) / 环戊烷 (Cyclopentane) / 不含氟氯烃 (CFC Free)		
温度控制类型/Temperature control type	数字温控/Digital		
电流/Amps (A)	4.6	5	5
电源/Voltage(V/Hz/Ph)	220V / 50 / 1		
功率/Power(W)	800	880	950
重量/Weight (Kg)	175	215	253

风幕柜 OPEN CASE

TOL-1200

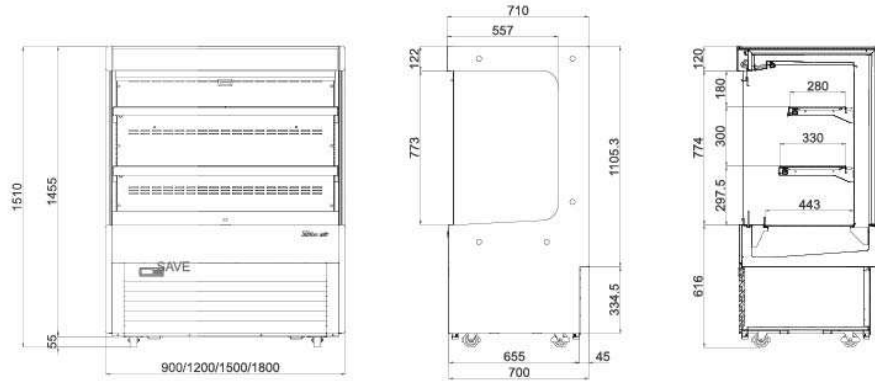

TOL-900



TOL-1500



TOL-1800



型号/Model	TOL-900	TOL-1200	TOL-1500	TOL-1800
分类/Classification	冷藏 (Refrigerator)			
外观尺寸/Cabinet Dimensions(W*D*H,mm)	900 x 700 x 1510	1200 x 700 x 1510	1500 x 700 x 1510	1800 x 700 x 1510
容量/Capacity (Liters)	211	288	345	442
柜内温度/Inner Temperature (°C)	5 °C ~ 10 °C			
搁物架数量/# of shelves	2			
制冷剂/frigerant	R-404A			
压缩机/Comperssor(HP)	3/4	1	1	1
制冷方式/Cooling Type	风冷/Fan cooling type			
隔热方式/Isullation Type	整体高密度发泡 (Polyurethane) / 环戊烷 (Cyclopentane) / 不含氟氯烃 (CFC Free)			
温度控制类型/Temperature control type	数字温控/Digital			
电流/Amps (A)	5	5.5	5.9	6.4
电源/Voltage(V/Hz/Ph)	220V / 50 / 1			
功率/Power(W)	880	950	1050	1100
重量/Weight (Kg)	180	220	250	280

弧形风幕柜 OPEN ROUND CASE

BAKERY CASE

TBA-1200

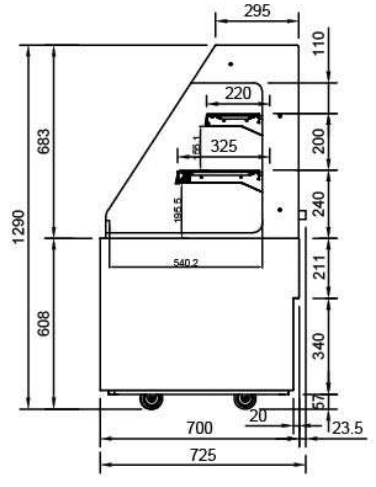
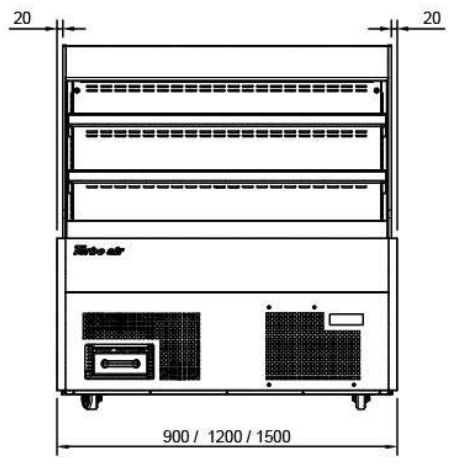

COMBI SHOWCASE

SANDWICH CASE

CHOCOLATE CASE

OPEN CASE

TBA-900



TBA-1500



ICE MAKER

CELATO SHOW CASE

BAKING LINE

型号/Model	TBA-900	TBA-1200	TBA-1500
分类/Classification	冷藏 (Refrigerator)		
外观尺寸/Cabinet Dimensions(W*D*H,mm)	900x700x1290	1200x700x1290	1500x700x1290
容量/Capacity (Liters)	150	205	260
柜内温度/Inner Temperature (°C)	5 °C ~ 10 °C		
搁物架数量/# of shelves	3(4Layer)		
制冷剂/frigerant	R-404A		
压缩机/Comperssor(HP)	3/4		
制冷方式/Cooling Type	风冷/Fan cooling type		
隔热方式/Isullation Type	整体高密度发泡 (Polyurethane) / 环戊烷 (Cyclopentane) / 不含氟氯烃 (CFC Free)		
温度控制类型/Temperature control type	数字温控/Digital		
电流/Amps (A)	3.6	4.5	5.0
电源/Voltage(V/Hz/Ph)	220V / 50 / 1		
功率/Power(W)	670	830	850
重量/Weight (Kg)	170	220	260

REACH-IN REFRIGERATORS & FREEZERS

Table of Contents

K - Series

- Refrigerator / Freezer
- Dual Temperature
- Bun Pan
- Glass doors

Pro - Series

- Refrigerator / Freezer

M3 - Series

- Refrigerator / Freezer



1



2

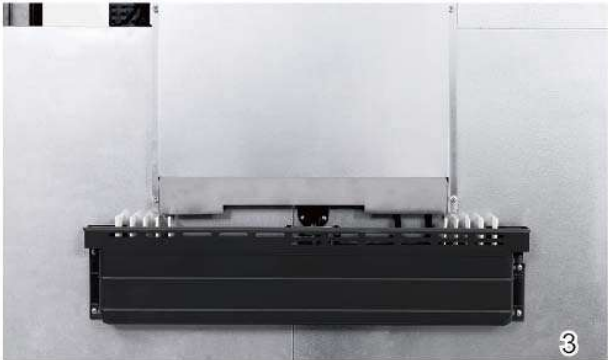

3

- 1. Fan Control System
- 2. Front Digital Controller
- 3. Drain water evaporation system
- 4. Easy grip recessed door handle



4



5

- 5. PE coated Shelf
- 6. High Efficient Compressor System
- 7. LED interior
- 8. Self closing and stay open door



6



7



8

K-Series

TOP MOUNT [K.P.M3]

UNDER COUNTER [K.M3]

SALAD PREP [BUFFET.HOOD LID]

PIZZA TABLE

CHEF BASE

KR25-1
KF25-1



KR45-2
KF45-2



KR65-3
KF65-3



型号 / MODEL	KR25-1 KF25-1	KR25-2 KF25-2	KR45-2 KF45-2	KR45-4 KF45-4	KR65-3 KF65-3	KR65-6 KF65-6
分类 / Classification	冷藏 (Refrigerator) 冷冻 (Freezer)					
外形尺寸 / Cabinet dimension (WxDxH mm)	640x850x1926	640x850x1926	1260x850x1926	1260x850x1926	1900x850x1926	1900x850x1926
容量 / Capacity (Liters)	574	572	1215	1210	1876	1868
柜内温度 / Inner Temperature	1°C~8°C -21°C~-12°C					
门数 / Doors	1	2	2	4	3	6
搁物架数量 / # of shelves	3	3	6	6	9	9
制冷剂 / Refrigerant	R134a R404A					
压缩机 / Compressor (Hp)	1/4 2/3	1/4 2/3	1/3 1	1/3 1	3/4 3/4x2	3/4 3/4x2
制冷方式 / Cooling Type	风冷式 (Fan cooling type)					
隔热方式 / Insulation Type	整体高密度发泡 (Polyurethane) / 环戊烷 (Cyclopentane) + 不含氟氯烃 (CFC Free)					
温度设定方式 / Temperature Control Type	数字控温 (Digital)					
电流 / Amps (A)	2.8 3.5	2.8 3.5	3.5 5.3	3.5 5.3	6 8.5	6 8.5
电源 / Voltage (V/Hz/Ph)	220V 50Hz 1Ph					
功率 / Power (W)	314 496	314 496	366 774	366 774	732 1346	732 1346
重量 / Weight (Kg)	77 80	77 80	142 142	142 142	167 167	167 167

Top Mount

KR25-2
KF25-2

KR45-4
KF45-4

KR65-6
KF65-6

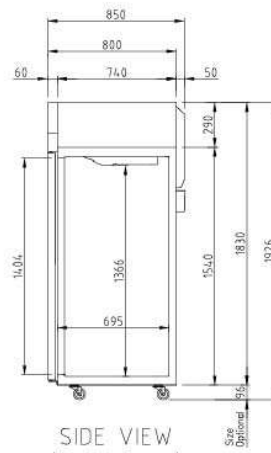
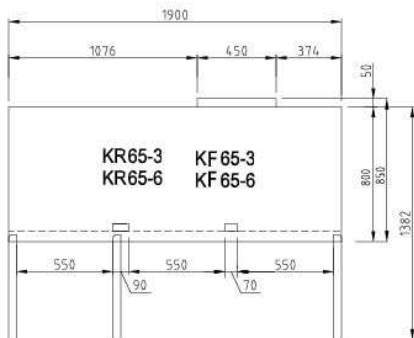
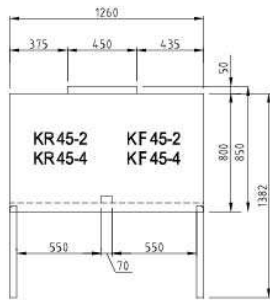
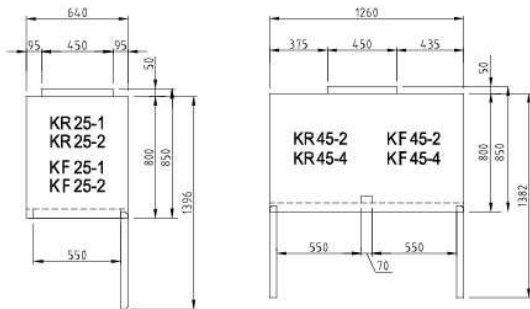

SIDE VIEW
(Solid Door)

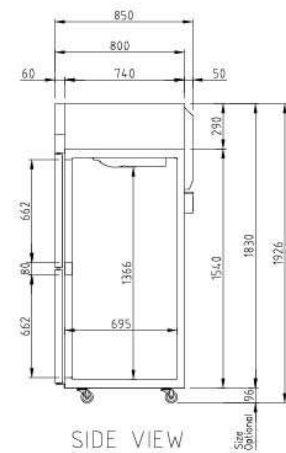

SIDE VIEW
(Half Solid Door)

K-Series **Dual Temperature**

TOP MOUNT [K.P.M3]

UNDER COUNTER [K.M3]

SALAD PREP [BUFFET.HOOD LID]

PIZZA TABLE

CHEF BASE

KRF25-2

KFR25-2

KRF45-2H

KRF65-3



型号 / MODEL	KRF25-2 KFR25-2	KRF45-2H KRF45-4H	KRF65-3 KRF65-6 KRF65-6F
分类 / Classification	冷藏 / 冷冻 (Refrigerator / Freezer)		
外形尺寸 / Cabinet dimension (WxDxH mm)	640x x1926	1260x x1926	1900x x1926
容量 / Capacity (Liters)	242/222	576/576	575/1235
柜内温度 / Inner Temperature	1°C~8°C -21°C~-12°C		
门数 / Doors	2	2/4	3/6/6
搁物架数量 / # of shelves	1/1	3/3	3/6
制冷剂 / Refrigerant	R404A	R134a/R404A	R134a/R404A
压缩机 / Compressor (Hp)	1/2	1/3 1/2	1/3 3/4
制冷方式 / Cooling Type	风冷式 (Fan cooling type)		
隔热方式 / Insulation Type	整体高密度发泡 (Polyurethane) / 环戊烷 (Cyclopentane) + 不含氯氟烃 (CFC Free)		
温度设定方式 / Temperature Control Type	数字控温 (Digital)		
电流 / Amps (A)	3.5	4.5	5.5
电源 / Voltage (V/Hz/Ph)	220V 50Hz 1Ph		
功率 / Power (W)	366	732	1098
重量 / Weight (Kg)	85	152	177

KRF45-4H

KRF65-6

KRF65-6F

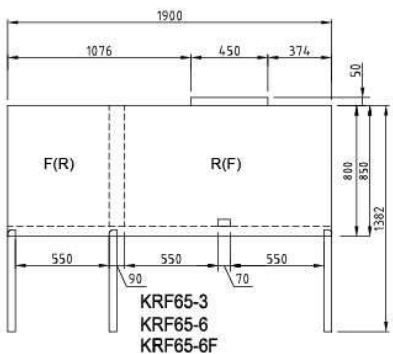
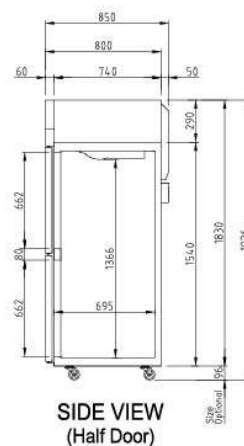
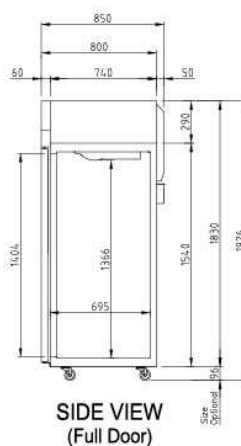
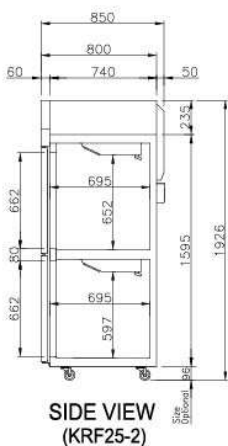
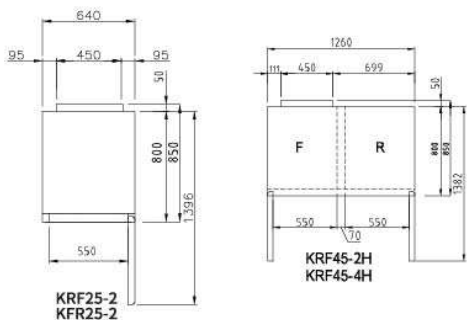

K-Series Bun Pan

TOP MOUNT [K.P.M3]

UNDER COUNTER [K.M3]

SALAD PREP [BUFFET HOOD LID]

PIZZA TABLE

CHEF BASE

KR25-1P
KF25-1P



KR45-2P
KF45-2P



KR65-3P
KF65-3P



型号 / MODEL	KR25-1P	KR25-2P	KR45-2P	KR45-4P	KR65-3P	KR65-6P
	KF25-1P	KF25-2P	KF45-2P	KF45-4P	KF65-3P	KF65-6P
分类 / Classification	冷藏 (Refrigerator)					
	冷冻 (Freezer)					
外形尺寸 / Cabinet dimension (WxDxH mm)	640x850x1926	640x850x1926	1260x850x1926	1260x850x1926	1900x850x1926	1900x850x1926
容量 / Capacity (Liters)	574	572	1215	1210	1876	1868
柜内温度 / Inner Temperature	1°C~8°C					
	-21°C~-12°C					
门数 / Doors	1	2	2	4	3	6
搁物架数量 / # of shelves	3	3	6	6	9	9
制冷剂 / Refrigerant	R134a					
	R404A					
压缩机 / Compressor (Hp)	1/4	1/4	1/3	1/3	3/4	3/4
	2/3	2/3	1	1	3/4x2	3/4x2
制冷方式 / Cooling Type	风冷式 (Fan cooling type)					
隔热方式 / Insulation Type	整体高密度发泡 (Polyurethane) / 环戊烷 (Cyclopentane) + 不含氯氟烃 (CFC Free)					
温度设定方式 / Temperature Control Type	数字控温 (Digital)					
电流 / Amps (A)	2.8	2.8	3.5	3.5	6	6
	3.5	3.5	5.3	5.3	8.5	8.5
电源 / Voltage (V/Hz/Ph)	220V 50Hz 1Ph					
功率 / Power (W)	314	314	366	366	732	732
	496	496	774	774	1346	1346
重量 / Weight (Kg)	77	77	142	142	167	167
	80	80	142	142	167	167

Top Mount

KR25-2P
KF25-2P

KR45-4P
KF45-4P

KR65-6P
KF65-6P

Bun PAN数量
K25:14EA
K45:28EA
K65:42EA

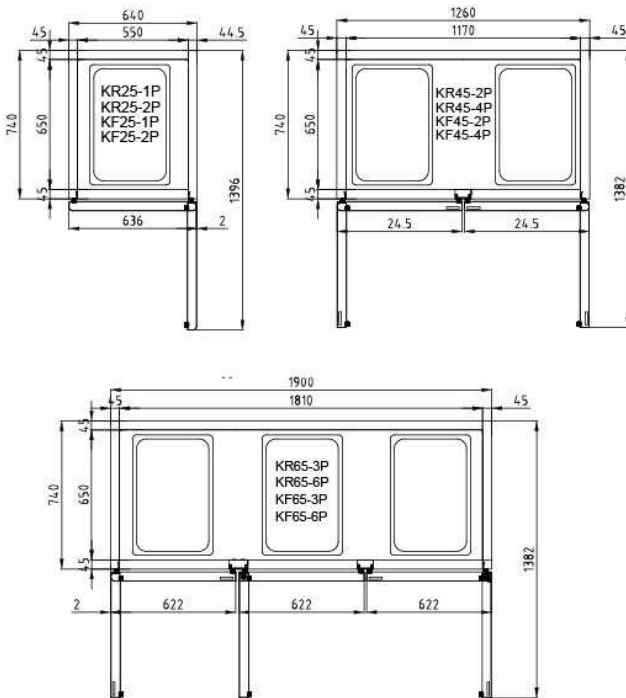

Bun PAN

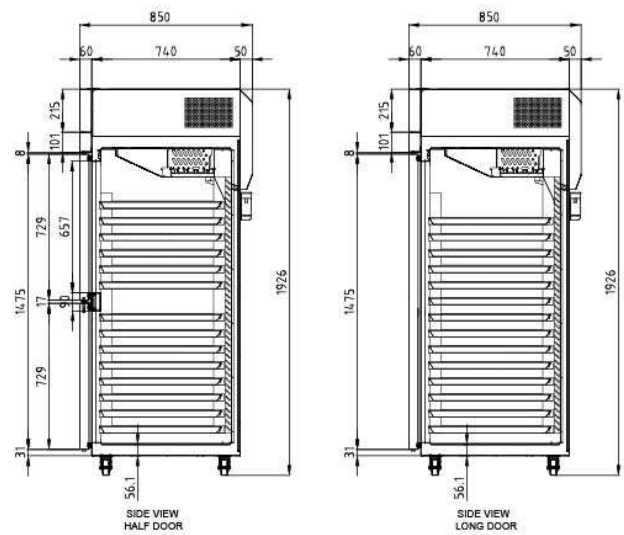

K-Series Dual Bun Pan

TOP MOUNT [K.P.M3]

UNDER COUNTER [K.M3]

SALAD PREP [BUFFET HOOD LID]

PIZZA TABLE

CHEF BASE

KRF25-2P



KRF45-2HP



KRF65-3P



型号 / MODEL	KRF25-2P	KRF45-2HP KRF45-4HP	KRF65-6P KRF65-6FP
分类 / Classification	冷藏 / 冷冻 (Refrigerator / Freezer)		
外形尺寸 / Cabinet dimension (WxDxH mm)	640x850x1926	1260x850x1926	1900x850x1926
容量 / Capacity (Liters)	242/222	576/576	575/1235
柜内温度 / Inner Temperature	1°C~8°C / -21°C~-12°C		
门数 / Doors	2	4	6
搁物架数量 / # of shelves	1/1	3/3	6/3
制冷剂 / Refrigerant	R404A	R134a/R404A	R134a/R404A
压缩机 / Compressor (Hp)	1/2	1/3 1/2	1/3 3/4
制冷方式 / Cooling Type	风冷式 (Fan cooling type)		
隔热方式 / Insulation Type	整体高密度发泡 (Polyurethane) / 环戊烷 (Cyclopentane) + 不含氯氟烃 (CFC Free)		
温度设定方式 / Temperature Control Type	数字控温 (Digital)		
电流 / Amps (A)	3.5	4.5	5.5
电源 / Voltage (V/Hz/Ph)	220V 50Hz 1Ph		
功率 / Power (W)	366	732	1098
重量 / Weight (Kg)	85	152	177

Bun PAN数量
 K25:14EA
 K45:28EA
 K65:42EA

KRF45-4HP

KRF65-6P

KRF65-6FP

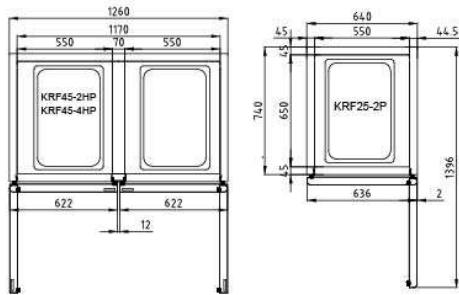

Bun PAN

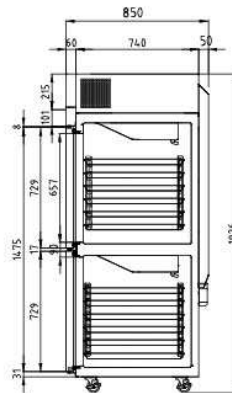
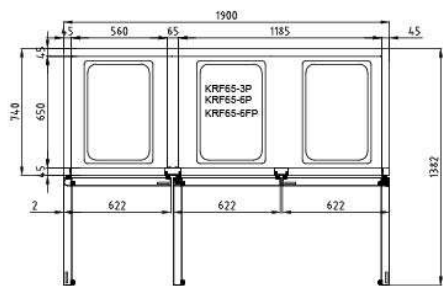

SIDE VIEW
KRF25-2P

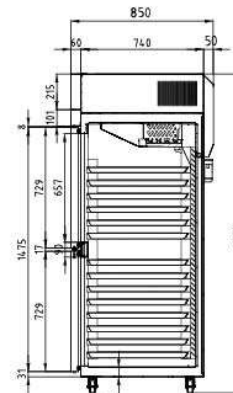

SIDE VIEW
HALF DOOR

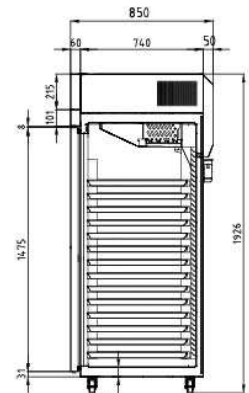

SIDE VIEW
LONG DOOR

K-Series Glass door

TOP MOUNT [K.P.M3]

UNDER COUNTER [K.M3]

SALAD PREP [BUFFET.HOOD LID]

PIZZA TABLE

CHEF BASE

KR25-1G

KF25-1G

KR45-2G

KF45-2G

KR65-3G



型号 / MODEL	KR25-1G KF25-1G	KR25-2G KF25-2G	KR45-2G KF45-2G	KR45-4G KF45-4G	KR65-3G	KR65-6G
分类 / Classification	冷藏 / 冷冻 (Refrigerator / Freezer)					
外形尺寸 / Cabinet dimension (WxDxH mm)	640x850x1926	640x850x1926	1260x850x1926	1260x850x1926	1900x850x1926	1900x850x1926
容量 / Capacity (Liters)	574	572	1215	1210	1876	1868
柜内温度 / Inner Temperature	1°C~8°C -21°C~-12°C					
门数 / Doors	1	2	2	4	3	6
搁物架数量 / # of shelves	3	3	6	6	9	9
制冷剂 / Refrigerant	R134a R404A					
压缩机 / Compressor (Hp)	1/4 6/7	1/4 6/7	1/3 2/3x2	1/3 2/3x2	1/3x2	1/3x2
制冷方式 / Cooling Type	风冷式 (Fan cooling type)					
隔热方式 / Insulation Type	整体高密度发泡 (Polyurethane) / 环戊烷 (Cyclopentane) + 不含氯氟烃 (CFC Free)					
温度设定方式 / Temperature Control Type	数字控温 (Digital)					
电流 / Amps (A)	2.8 4.5	2.8 4.5	2.9 8	3.5 8	6	6
电源 / Voltage (V/Hz/Ph)	220V 50Hz 1Ph					
功率 / Power (W)	314 660	314 660	365.4 976	366 976	732	732
重量 / Weight (Kg)	87 95	87 95	152 170	152 170	177	177

KR25-2G
KF25-2G



KR45-4G
KF45-4G



KR65-6G

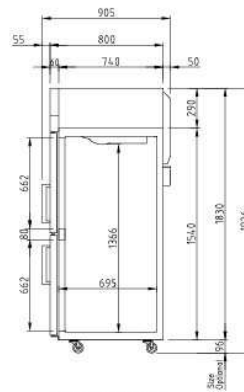
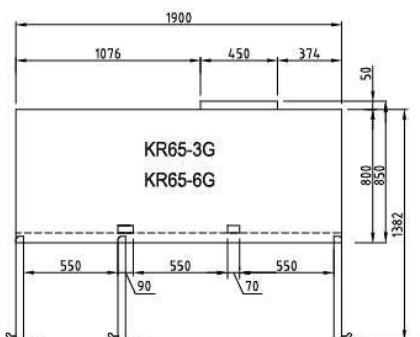
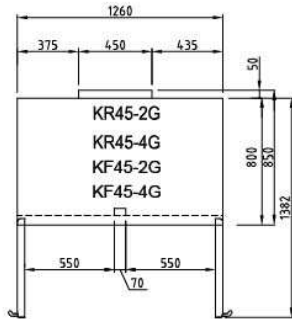
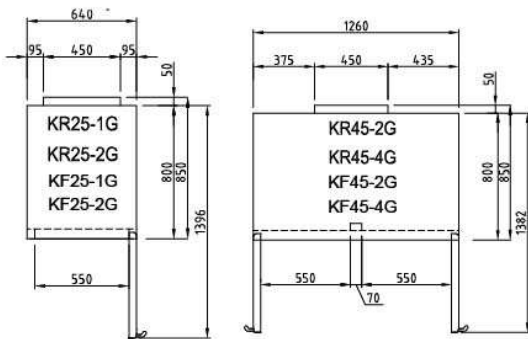

SIDE VIEW
(Half Glass Door)

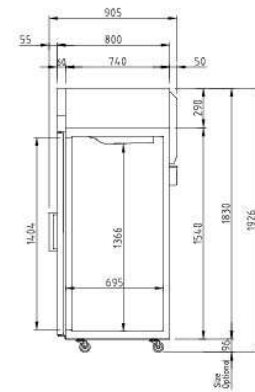

SIDE VIEW
(Glass Door)

M3-Series

TOP MOUNT [K.P.M3]

CM3R24-1
CM3F24-1

CM3R47-2
CM3F47-2

CM3R72-3
CM3F72-3



UNDER COUNTER [K.M3]

SALAD PREP [BUFFET HOOD LID]

PIZZA TABLE

CHEF BASE

型号 / MODEL	CM3R24-1 CM3F24-1 CM3R24-2 CM3F24-2	CM3R47-2 CM3F47-2 CM3R47-4 CM3F47-4	CM3R72-3 CM3F72-3 CM3R72-6 CM3F72-6
分类 / Classification	冷藏 / 冷冻 (Refrigerator / Freezer)		
外形尺寸 / Cabinet dimension (WxDxH mm)	730×780×2106	1314×780×2016	1976×780×2106
容量 / Capacity (Liters)	665	1277	1968
柜内温度 / Inner Temperature	1℃~8℃ / -25℃~-17℃		
门数 / Doors	1 2	2 4	3 6
搁物架数量 / # of shelves	3	6	9
制冷剂 / Refrigerant	R134a/R404A		
压缩机 / Compressor (Hp)	1/4 3/4	1/3 1	1 1-1/4
制冷方式 / Cooling Type	风冷式 (Fan cooling type)		
隔热方式 / Insulation Type	整体高密度发泡 (Polyurethane) / 环戊烷 (Cyclopentane) + 不含氟氯烃 (CFC Free)		
温度设定方式 / Temperature Control Type	数字控温 (Digital)		
电流 / Amps (A)	2.3 2.6	2.8 3.9	3.8 4.8
电源 / Voltage (V/Hz/Ph)	220V 50Hz 1Ph		
功率 / Power (W)	338 500	389 813	490 1050
重量 / Weight (Kg)	115 120	190 200	280 280



UNDER COUNTER WORK TOPS DRAWER

Table of Contents

K - Series

- Under Counter (700)
- Under Counter (600)
- Dual Temperature
- Bun Pan
- GN Pan
- Glass Door
- Drawer

M3 - Series

- Refrigerator / Freezer
- Drawers
- Low Boy



1



2

- 1. Fan Control Cooling System
- 2. Stainless Steel drawers
- 3. LED interior
- 4. Front Digital Controller



3



4



5



6

- 5. All Copper refrigeration System
- 6. Condenser easy Cleaning
- 7. Easy grip recessed door handle
- 8. PE Coated Shelf



7



8

K-Series Under Counter(700)

TOP MOUNT [K.P.M3]

UNDER COUNTER [K.M3]

SALAD PREP [BUFFET.HOOD LID]

PIZZA TABLE

CHEF BASE

KUR9-1
KUF9-1



OPTION



靠背 Work Top

KUR12-2
KUF12-2

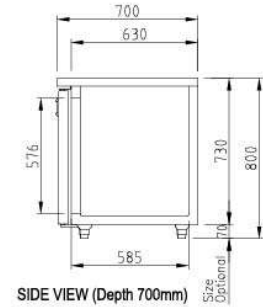
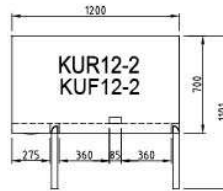

KUR15-2
KUF15-2

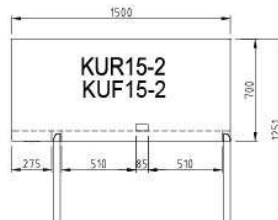

KUR18-3
KUF18-3

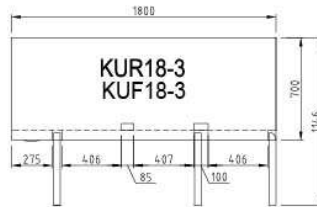

型号 / MODEL	KUR9-1 KUF9-1	KUR12-2 KUF12-2	KUR15-2 KUF15-2	KUR18-3 KUF18-3
分类 / Classification	冷藏 (Refrigerator) 冷冻 (Freezer)			
外形尺寸 / Cabinet dimension (WxDxH mm)	900x700x800	1200x700x800	1500x700x800	1800x700x800
容量 / Capacity (Liters)	198	311	425	538
柜内温度 / Inner Temperature	1°C~8°C -21°C~-12°C			
门数 / Doors	1	2	2	3
搁物架数量 / # of shelves	1	2	2	3
制冷剂 / Refrigerant	R134a			
	R134a	R404A	R404A	R404A
压缩机 / Compressor (Hp)	1/4 1/3	1/4 1/3	1/4 3/4	1/3 3/4
制冷方式 / Cooling Type	风冷式 (Fan cooling type)			
隔热方式 / Insulation Type	整体高密度发泡 (Polyurethane) / 环戊烷 (Cyclopentane) + 不含氯氟烃 (CFC Free)			
温度设定方式 / Temperature Control Type	数字控温 (Digital)			
电流 / Amps (A)	2.3	2.5	2.5	3.0
	2.3	2.5	3	4.4
电源 / Voltage (V/Hz/Ph)	220V 50Hz 1Ph			
功率 / Power (W)	314	314	314	366
	366	613	613	613
重量 / Weight (Kg)	72	84	93	109

Under Counter(600)

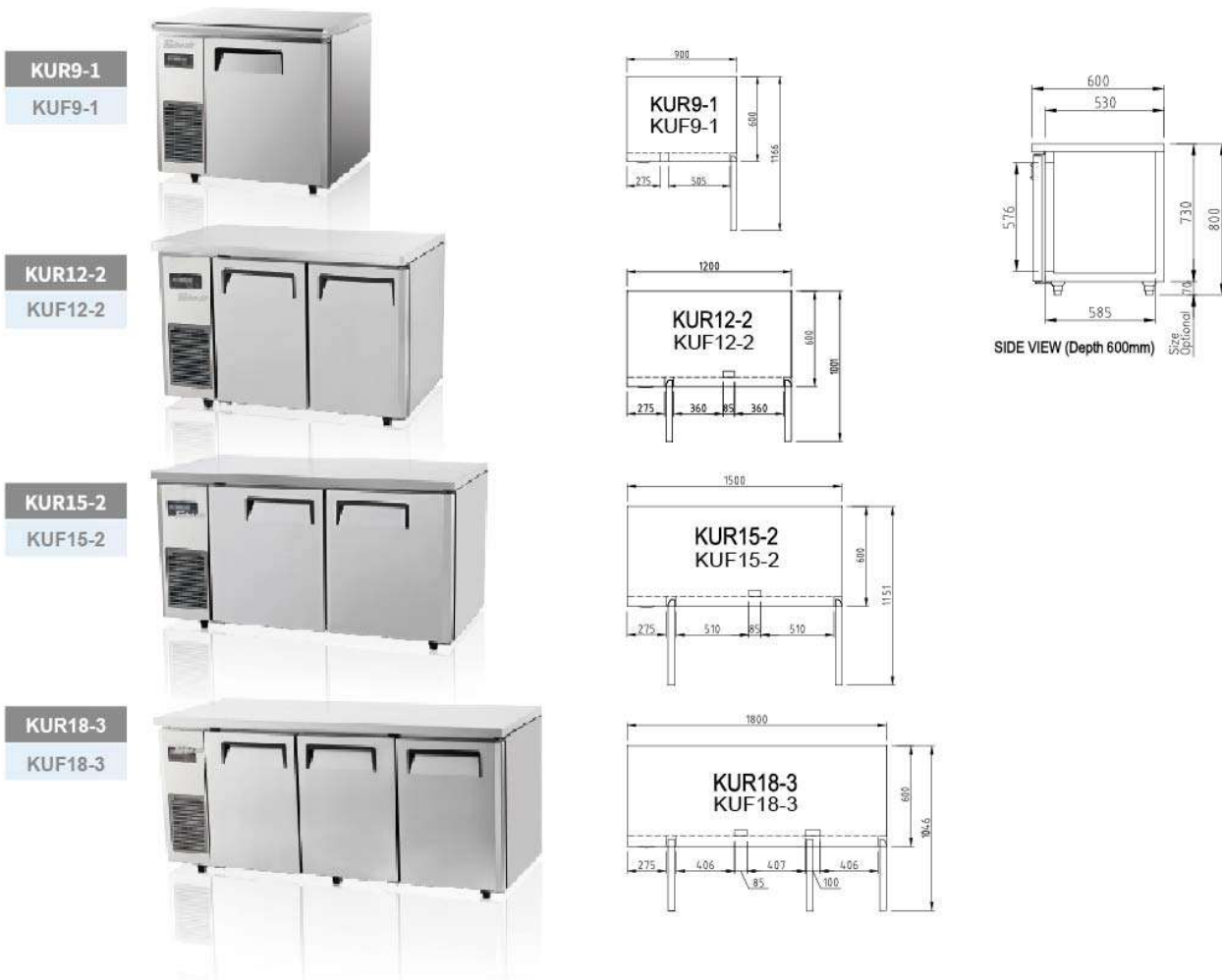

型号 / MODEL	KUR9-1 KUF9-1	KUR12-2 KUF12-2	KUR15-2 KUF15-2	KUR18-3 KUF18-3
分类 / Classification	冷藏 (Refrigerator)			
	冷冻 (Freezer)			
外形尺寸 / Cabinet dimension (WxDxH mm)	900x600x800	1200x600x800	1500x600 x800	1800x600 x800
容量 / Capacity (Liters)	179	253	345	487
柜内温度 / Inner Temperature	1°C~8°C			
	-21°C~-12°C			
门数 / Doors	1	2	2	3
搁物架数量 / # of shelves	1	2	2	3
制冷剂 / Refrigerant	R134a			
	R134a	R404A	R404A	R404A
压缩机 / Compressor (Hp)	1/4	1/4	1/4	1/3
	1/3	1/3	3/4	3/4
制冷方式 / Cooling Type	风冷式 (Fan cooling type)			
隔热方式 / Insulation Type	整体高密度发泡 (Polyurethane) / 环戊烷 (Cyclopentane) + 不含氯氟烃 (CFC Free)			
温度设定方式 / Temperature Control Type	数字控温 (Digital)			
电流 / Amps (A)	2.3	2.5	2.5	3.0
	2.3	2.5	3	4.4
电源 / Voltage (V/Hz/Ph)	220V 50Hz 1Ph			
功率 / Power (W)	314	314	314	366
	366	613	613	613
重量 / Weight (Kg)	61	71	79	92

Under Counter **Dual Temperature**

TOP MOUNT [K.P.M3]

UNDER COUNTER [K.M3]

SALAD PREP [BUFFET.HOOD LID]

PIZZA TABLE

CHEF BASE

KURF12-2

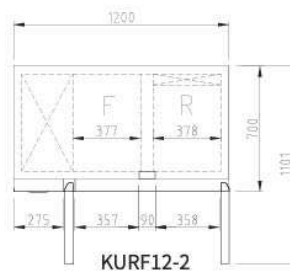

SIDE VIEW
(Depth 700mm)

KURF15-2

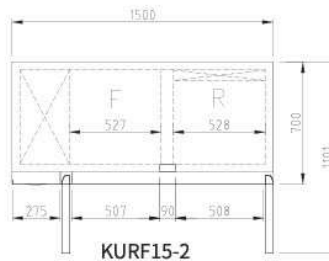

KURF18-3

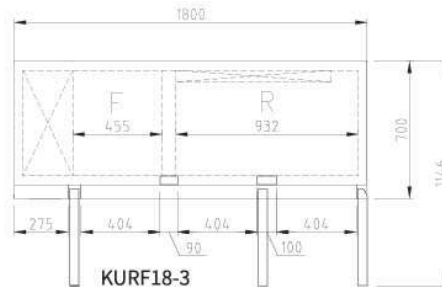

型号 / MODEL	KURF12-2		KURF15-2		KURF18-3	
	Refrigerator	Freezer	Refrigerator	Freezer	Refrigerator	Freezer
分类 / Classification	冷藏 / 冷冻 (Refrigerator / Freezer)					
外形尺寸 / Cabinet dimension (WxDxH mm)	1200x700x800		1500x700x800		1800x700x800	
容量 / Capacity (Liters)	121	136	171	191	151	287
柜内温度 / Inner Temperature	1°C~8°C	-21°C~-12°C	1°C~8°C	-21°C~-12°C	1°C~8°C	-21°C~-12°C
门数 / Doors	2		2		3	
搁物架数量 / # of shelves	1	1	1	1	2	1
制冷剂 / Refrigerant	R134a		R404A		R404A	
压缩机 / Compressor (Hp)	1/3		3/4		3/4	
制冷方式 / Cooling Type	风冷式 (Fan cooling type)					
隔热方式 / Insulation Type	整体高密度发泡 (Polyurethane) / 环戊烷 (Cyclopentane) + 不含氟氯烃 (CFC Free)					
温度设定方式 / Temperature Control Type	数字控温 (Digital)					
电流 / Amps (A)	3		4.35		4.4	
电源 / Voltage (V/Hz/Ph)	220V 50Hz 1Ph					
功率 / Power (W)	316		316		366	
重量 / Weight (Kg)	92		101		120	

Under Counter **Bun Pan**

KUR15-2P
KUF15-2P

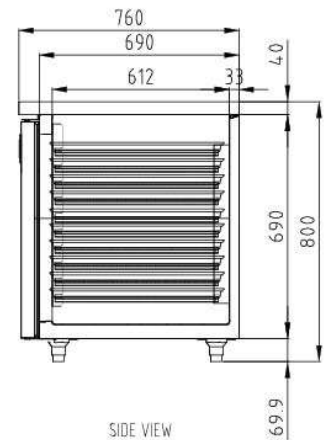
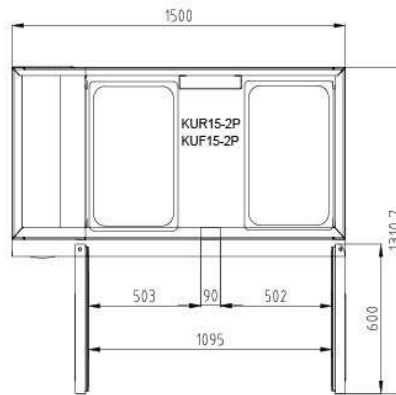

SIDE VIEW

Bun PAN数量
K15P:20EA
K18P:30EA

KUR18-3P
KUF18-3P

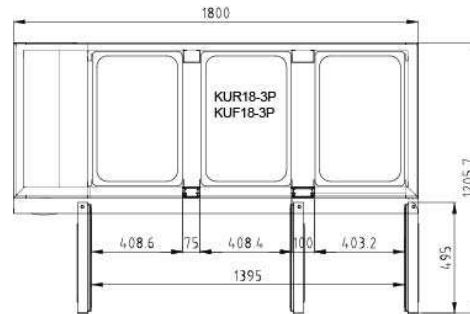

型号 / MODEL	KUR15-2P	KUF15-2P	KUR18-3P	KUF18-3P
分类 / Classification	冷藏 (Refrigerator)	冷冻 (Freezer)	冷藏 (Refrigerator)	冷冻 (Freezer)
外形尺寸 / Cabinet dimension (WxDxH mm)	1500×760×800		1800×760×800	
容量 / Capacity (Liters)	121	136	171	191
柜内温度 / Inner Temperature	1℃~8℃	-21℃~12℃	1℃~8℃	-21℃~12℃
门数 / Doors	2		3	
搁物架数量 / # of shelves	0	0	0	0
制冷剂 / Refrigerant	R134a	R404A	R404A	
压缩机 / Compressor (Hp)	1/4	3/4	1/3	3/4
制冷方式 / Cooling Type	风冷式 (Fan cooling type)			
隔热方式 / Insulation Type	整体高密度发泡 (Polyurethane) / 环戊烷 (Cyclopentane)			
温度设定方式 / Temperature Control Type	数字控温 (Digital)			
电流 / Amps (A)	2.5	3	3.0	4.4
电源 / Voltage (V/Hz/Ph)	220V 50Hz 1Ph			
功率 / Power (W)	314	613	366	613
重量 / Weight (Kg)	96		115	

Under Counter GN Pan

TOP MOUNT [K.P.M3]

UNDER COUNTER [K.M3]

SALAD PREP [BUFFET.HOOD LID]

PIZZA TABLE

CHEF BASE

KUR9-1



KUR12-2



KUR15-2



KUR18-3

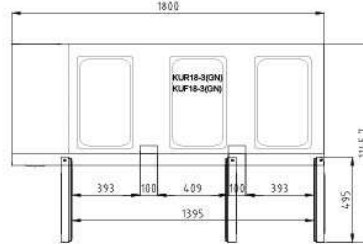
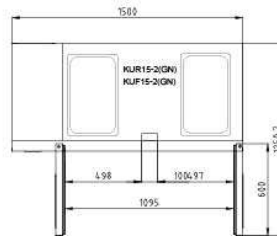
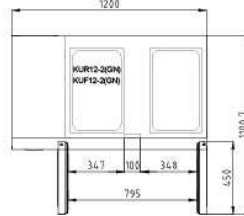

GN PAN

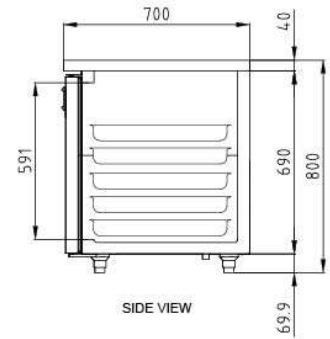

型号 / MODEL	KUR9-1(GN) KUF9-1(GN)	KUR12-2(GN) KUF12-2(GN)	KUR15-2(GN) KUF15-2(GN)	KUR18-3(GN) KUF18-3(GN)
分类 / Classification	冷藏 (Refrigerator)			
	冷冻 (Freezer)			
外形尺寸 / Cabinet dimension (WxDxH mm)	900x700x800	1200x700x800	1500x700x800	1800x700x800
容量 / Capacity (Liters)	198	311	425	538
柜内温度 / Inner Temperature	1°C~8°C			
	-21°C~-12°C			
门数 / Doors	1	2	2	3
搁物架数量 / # of shelves	1	2	2	3
制冷剂 / Refrigerant	R134a			
	R134a	R404A	R404A	R404A
压缩机 / Compressor (Hp)	1/4	1/4	1/4	1/3
	1/3	1/3	3/4	3/4
制冷方式 / Cooling Type	风冷式 (Fan cooling type)			
隔热方式 / Insulation Type	整体高密度发泡 (Polyurethane) / 环戊烷 (Cyclopentane) + 不含氯氟烃 (CFC Free)			
温度设定方式 / Temperature Control Type	数字控温 (Digital)			
电流 / Amps (A)	2.3	2.5	2.5	3.0
电源 / Voltage (V/Hz/Ph)	2.3	2.5	3	4.4
	220V 50Hz 1Ph			
功率 / Power (W)	314	314	314	366
	366	613	613	613
重量 / Weight (Kg)	72	84	93	109

Under Counter **Glass Door**

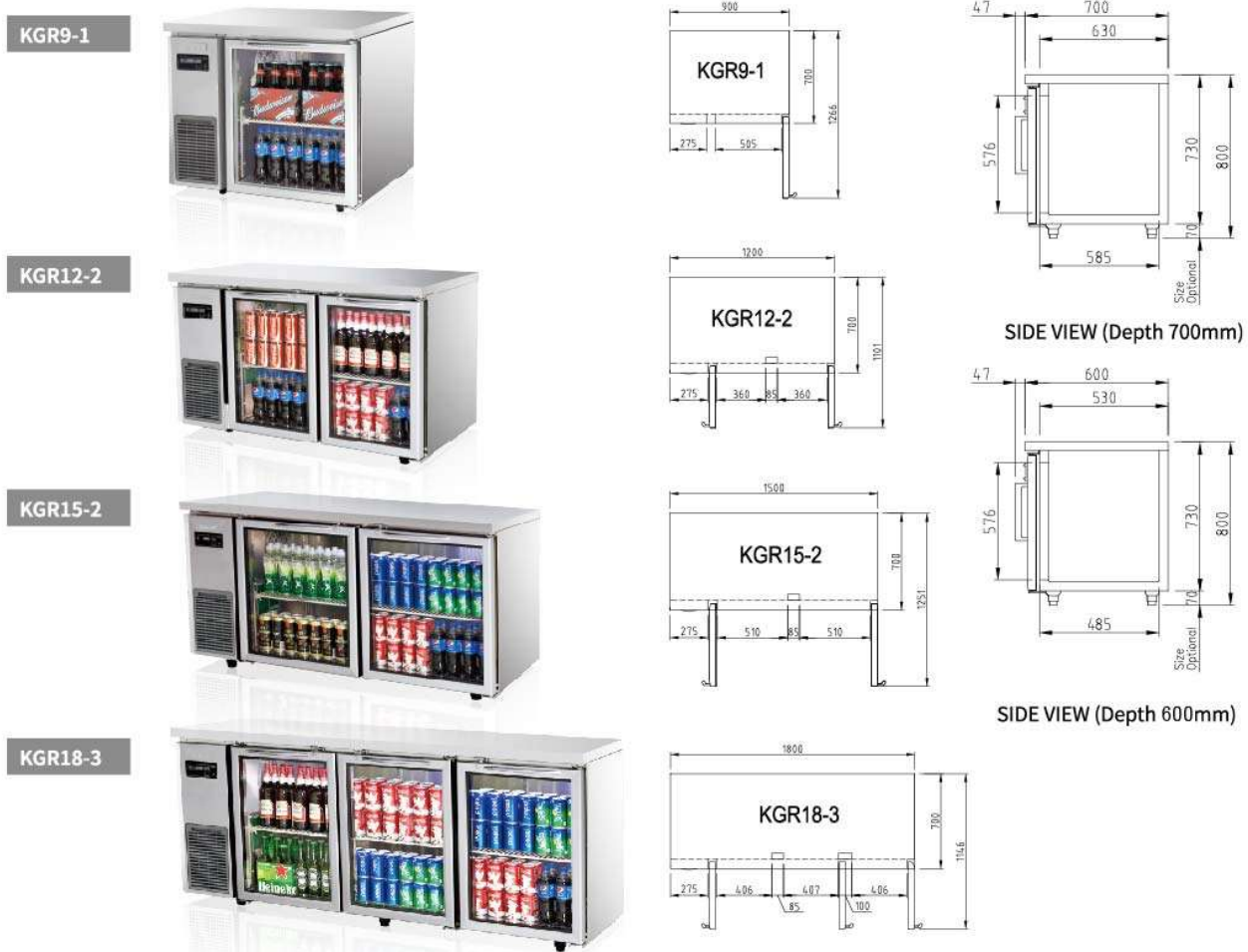

型号 / MODEL	KGR9-1	KGR12-2	KGR15-2	KGR18-3
分类 / Classification	冷藏 (Refrigerator)			
外形尺寸 / Cabinet dimension (WxDxH mm)	900x700(600)x800	1200x700(600)x800	1500x700(600)x800	1800x700(600)x800
容量 / Capacity (Liters)	121	309	420	516
柜内温度 / Inner Temperature	1°C~8°C			
门数 / Doors	1	2	2	3
搁物架数量 / # of shelves	1	2	2	3
制冷剂 / Refrigerant	R134a			
压缩机 / Compressor (Hp)	1/4	1/4	1/4	1/3
制冷方式 / Cooling Type	风冷式 (Fan cooling type)			
隔热方式 / Insulation Type	整体高密度发泡 (Polyurethane) / 环戊烷 (Cyclopentane) + 不含氯氟烃 (CFC Free)			
温度设定方式 / Temperature Control Type	数字控温 (Digital)			
电流 / Amps (A)	2.3	2.5	2.5	3.0
电源 / Voltage (V/Hz/Ph)	220V 50Hz 1Ph			
功率 / Power (W)	314	314	314	366
重量 / Weight (Kg)	80	96	110	127

Under Counter **Drawer**

TOP MOUNT [K.P.M3]

UNDER COUNTER [K.M3]

SALAD PREP [BUFFET.HOOD LID]

PIZZA TABLE

CHEF BASE

KUR9-3D-3
KUF9-3D-3



KUR12-3D-3
KUF12-3D-3



KUR12-3D-6
KUF12-3D-6



KUR15-3D-3
KUF15-3D-3

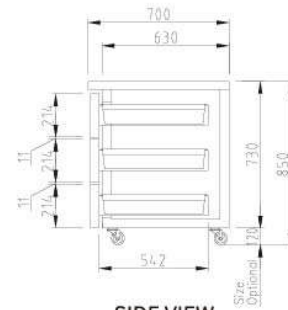
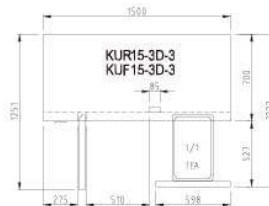
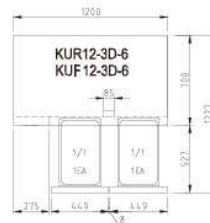

SIDE VIEW
(Depth 700mm)

OPTION

2 Drawer Available



型号 / MODEL	KUR9-3D-3 KUF9-3D-3	KUR12-3D-3 KUF12-3D-3	KUR12-3D-6 KUF12-3D-6	KUR15-3D-3 KUF15-3D-3
分类 / Classification	冷藏 (Refrigerator)			
	冷冻 (Freezer)			
外形尺寸 / Cabinet dimension (WxDxH mm)	900x700x850	1200x700x850	1200x700x850	1500x700x850
容量 / Capacity (Liters)	198	311	311	425
柜内温度 / Inner Temperature	1°C~8°C			
	-21°C~-12°C			
门数 / Doors	0	1	0	1
搁物架数量 / # of shelves	0	1	0	1
制冷剂 / Refrigerant	R134a			
	R134a	R134a	R134a	R404A
压缩机 / Compressor (Hp)	1/4	1/4	1/4	1/4
	1/3	1/3	1/3	3/4
制冷方式 / Cooling Type	风冷式 (Fan cooling type)			
隔热方式 / Insulation Type	整体高密度发泡 (Polyurethane) / 环戊烷 (Cyclopentane) + 不含氯氟烃 (CFC Free)			
温度设定方式 / Temperature Control Type	数字控温 (Digital)			
电流 / Amps (A)	2.3	2.5	2.5	2.5
	3	3.3	3.3	4.4
电源 / Voltage (V/Hz/Ph)	220V 50Hz 1Ph			
功率 / Power (W)	314	314	314	314
	366	366	366	366
重量 / Weight (Kg)	84	97	106	107

Under Counter **Drawer**

KUR15-3D-6
KUF15-3D-6



KUR18-3D-3



KUR18-3D-6



KUR18-3D-9

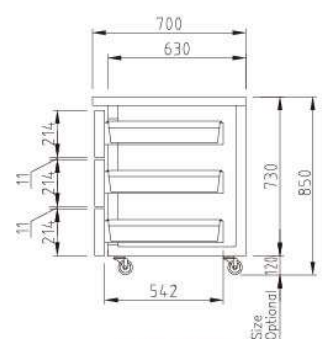
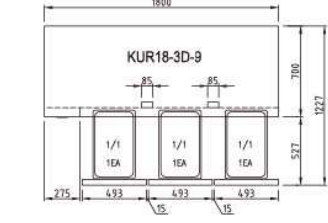
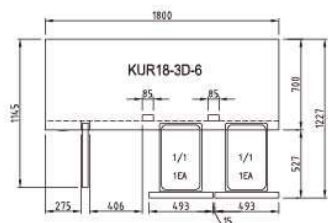
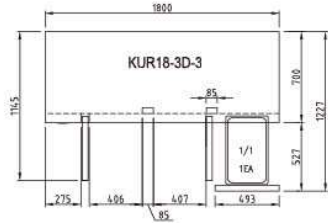
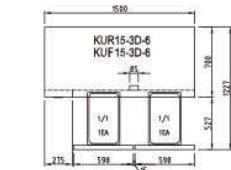

SIDE VIEW
(Depth 700mm)

MODEL	KUR15-3D-6 KUF15-3D-6	KUR18-3D-3	KUR18-3D-6	KUR18-3D-9
分类 / Classification	冷藏 (Refrigerator) 冷冻 (Freezer)			
外形尺寸 / Cabinet dimension (WxDxH mm)	1500x700x850	1800x700x850	1800x700x850	1800x700x850
容量 / Capacity (Liters)	425	538	538	538
柜内温度 / Inner Temperature	1°C~8°C -21°C~-12°C			
门数 / Doors	0	2	1	0
搁物架数量 / # of shelves	0	2	1	0
制冷剂 / Refrigerant	R134a			
压缩机 / Compressor (Hp)	R404A 1/4 3/4	1/3	1/3	1/3
制冷方式 / Cooling Type	风冷式 (Fan cooling type)			
隔热方式 / Insulation Type	整体高密度发泡 (Polyurethane) / 环戊烷 (Cyclopentane) + 不含氯氟烃 (CFC Free)			
温度设定方式 / Temperature Control Type	数字控温 (Digital)			
电流 / Amps (A)	2.5 4.4	3	3	3
电源 / Voltage (V/Hz/Ph)	220V 50Hz 1Ph			
功率 / Power (W)	314 366	366	366	366
重量 / Weight (Kg)	116	126	135	144

M3-Series Under Counter

TOP MOUNT [K.P.M3]

UNDER COUNTER [K.M3]

SALAD PREP [BUFFET-HOOD LID]

PIZZA TABLE

CHEF BASE

CMUR-28

CMUF-28



CMUR-48

CMUF-48



CMUR-60

CMUF-60

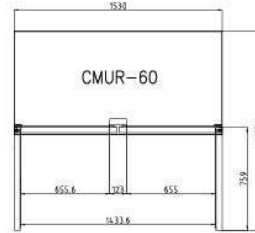

CMUR-72

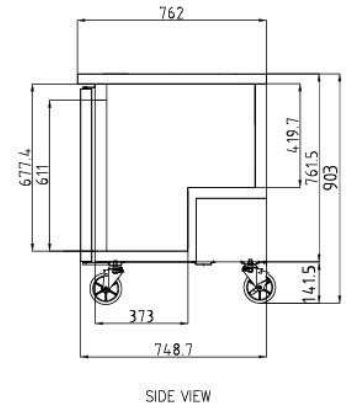
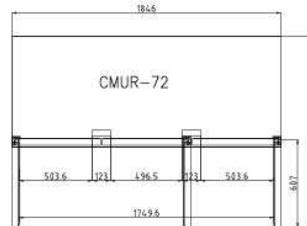

型号 / MODEL	CMUR-28 CMUF-28	CMUR-48 CMUF-48	CMUR-60 CMUF-60	CMUR-72
分类 / Classification	冷藏 (Refrigerator)			
	冷冻 (Freezer)			
外形尺寸 / Cabinet dimension (WxDxH mm)	698x762x903	1225x762x903	1530x762x903	1846x762x903
容量 / Capacity (Liters)	184	340	506	538
柜内温度 / Inner Temperature	1°C~8°C			
	-25°C~-17°C			
门数 / Doors	1	2	2	3
搁物架数量 / # of shelves	1	2	2	3
制冷剂 / Refrigerant	R134a			
	R134a	R404A	R404A	
压缩机 / Compressor (Hp)	1/4	1/3	1/3	1/3
	1/3	1/2	1/2	
制冷方式 / Cooling Type	风冷式 (Fan cooling type)			
隔热方式 / Insulation Type	整体高密度发泡 (Polyurethane) / 环戊烷 (Cyclopentane) + 不含氯氟烃 (CFC Free)			
温度设定方式 / Temperature Control Type	数字控温 (Digital)			
电流 / Amps (A)	2.8	3.5	3.8	5.3
	3	4	5.3	
电源 / Voltage (V/Hz/Ph)	220V 50Hz 1Ph			
功率 / Power (W)	314	366	440	440
	314	477	477	
重量 / Weight (Kg)	85	105	135	160

M3-Series Under Counter **Drawer**

CMUR-28-D2
CUMF-28-D2

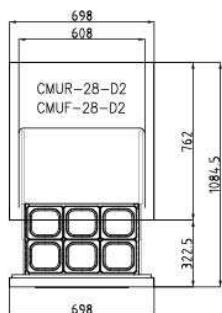

CMUR-48-D2
CMUF-48-D2

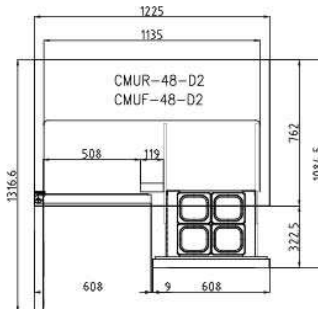

CMUR-48-D4
CMUF-48-D4

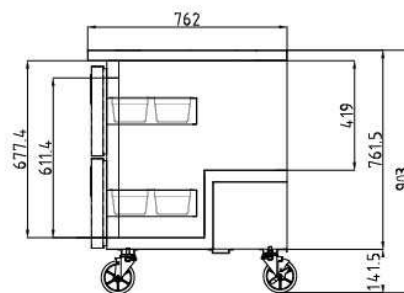
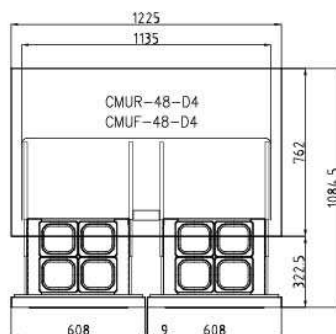

SIDE VIEW

型号 / MODEL	CMUR-28-D2 CUMF-28-D2	CMUR-48-D2 CMUF-48-D2	CMUR-48-D4 CMUF-48-D4
分类 / Classification	冷藏 (Refrigerator)		
	冷冻 (Freezer)		
外形尺寸 / Cabinet dimension (WxDxH mm)	698x762x903	1225x762x903	1225x762x903
容量 / Capacity (Liters)	184	340	340
柜内温度 / Inner Temperature	1°C~8°C		
	-25°C~-17°C		
门数 / Doors	0	1	0
搁物架数量 / # of shelves	0	1	0
制冷剂 / Refrigerant	R134a		
	R134a	R404A	R404A
压缩机 / Compressor (Hp)	1/4	1/3	1/3
	1/3	1/2	1/2
制冷方式 / Cooling Type	风冷式 (Fan cooling type)		
隔热方式 / Insulation Type	整体高密度发泡 (Polyurethane) / 环戊烷 (Cyclopentane) + 不含氯氟烃 (CFC Free)		
温度设定方式 / Temperature Control Type	数字控温 (Digital)		
电流 / Amps (A)	2.8	3.5	3.5
	3.8	3.5	6
电源 / Voltage (V/Hz/Ph)	220V 50Hz 1Ph		
功率 / Power (W)	314	366	366
	366	477	477
重量 / Weight (Kg)	90	110	115

Under Counter **Low Boy**

TOP MOUNT [K.P.M3]

CMUR-28L

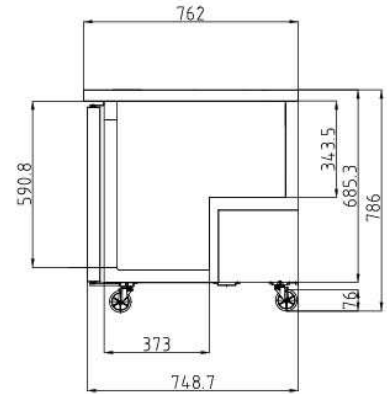
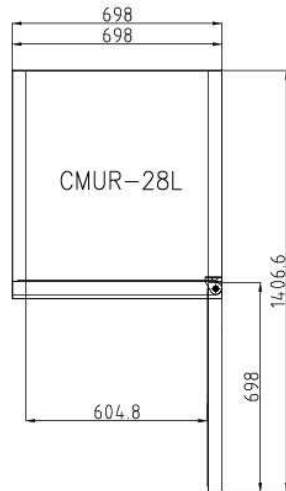

SIDE VIEW

UNDER COUNTER [K.M3]

CMUR-36L

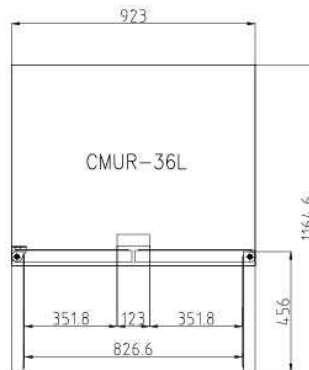

SALAD PREP [BUFFET, HOOD LID]

PIZZA TABLE

CHEF BASE

型号 / MODEL	CMUR-28L	CMUR-36L
分类 / Classification	冷藏 (Refrigerator)	
外形尺寸 / Cabinet dimension (WxDxH mm)	698x762x786	923x762x786
容量 / Capacity (Liters)	175	236
柜内温度 / Inner Temperature	1°C~8°C	
门数 / Doors	1	2
搁物架数量 / # of shelves	1	2
制冷剂 / Refrigerant	R134a	
压缩机 / Compressor (Hp)	1/4	1/4
制冷方式 / Cooling Type	风冷式 (Fan cooling type)	
隔热方式 / Insulation Type	整体高密度发泡 (Polyurethane) / 环戊烷 (Cyclopentane) + 不含氯氟烃 (CFC Free)	
温度设定方式 / Temperature Control Type	数字控温 (Digital)	
电流 / Amps (A)	2.8	2.8
电源 / Voltage (V/Hz/Ph)	220V 50Hz 1Ph	
功率 / Power (W)	314	314
重量 / Weight (Kg)	75	89

FOOD PREP TABLES

Table of Contents

K - Series

- Salad Prep Table [BUFFET]
- Salad Prep Table [HOOD LID]

M3 - Series

- Salad Prep Table
- Mega Top Prep Table

Pizza - Table

Chef Base

K-Series Salad Prep Table [BUFFET]

TOP MOUNT [K.P.M.3]

UNDER COUNTER [K.M.3]

SALAD PREP [BUFFET, HOOD LID]

PIZZA TABLE

CHEF BASE

KSR9-1



KSR12-2

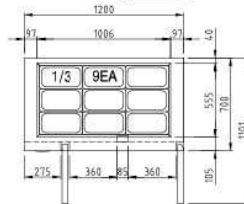

KSR15-2

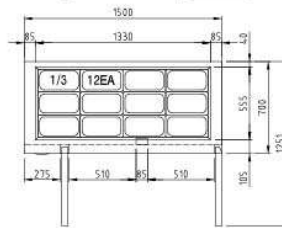

KSR18-3

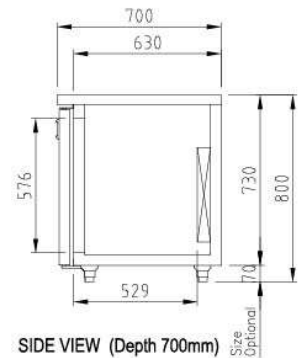
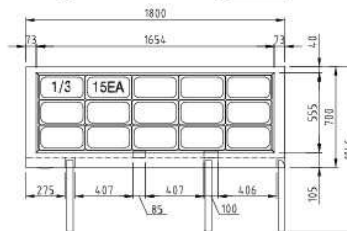

SIDE VIEW (Depth 700mm)

Size Optional

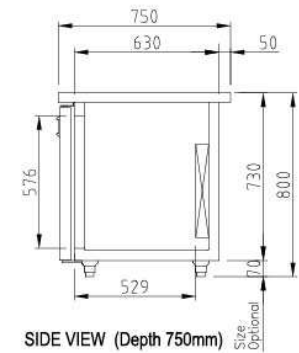

SIDE VIEW (Depth 750mm)

Size Optional

不包含菜盘

(Pans Not Included)

型号 / MODEL	KSR9-1	KSR12-2	KSR15-2	KSR18-3
分类 / Classification	冷藏 (Refrigerator)			
外形尺寸 / Cabinet dimension (WxDxH mm)	900x700x800	1200x700x800	1500x700x800	1800x700x800
容量 / Capacity (Liters)	213	309	420	516
柜内温度 / Inner Temperature	1°C~8°C			
门数 / Doors	1	2	2	3
搁物架数量 / # of shelves	1	2	2	3
制冷剂 / Refrigerant	R 134a			
压缩机 / Compressor (Hp)	1/4	1/4	1/4	1/3
制冷方式 / Cooling Type	风冷式 (Fan cooling type)			
隔热方式 / Insulation Type	整体高密度发泡 (Polyurethane) / 环戊烷 (Cyclopentane) + 不含氯氟烃 (CFC Free)			
温度设定方式 / Temperature Control Type	数字控温 (Digital)			
电流 / Amps (A)	2.3	2.5	2.5	3.0
电源 / Voltage (V/Hz/Ph)	220V 50Hz 1Ph			
功率 / Power (W)	314	314	314	366
重量 / Weight (Kg)	70	82	91	107

K-Series Salad Prep Table [HOOD LID]

KHR9-1

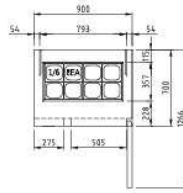

KHR12-2

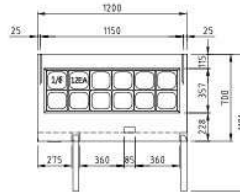

KHR15-2

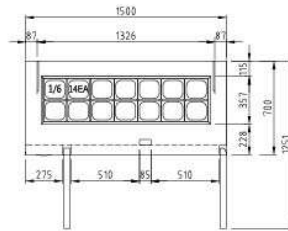

KHR18-3

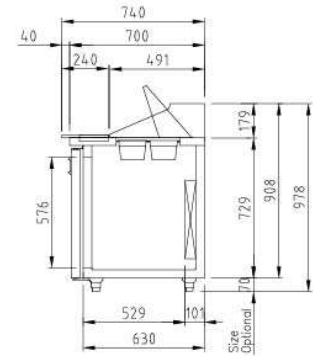
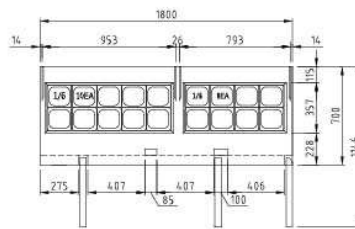

SIDE VIEW (Depth 700mm)

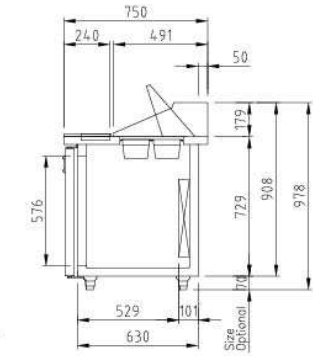

SIDE VIEW (Depth 750mm)

型号 / MODEL	KHR9-1	KHR12-2	KHR15-2	KHR18-3
分类 / Classification	冷藏 (Refrigerator)			
外形尺寸 / Cabinet dimension (WxDxH mm)	900x700x978	1200x700x978	1500x700x978	1800x700x978
容量 / Capacity (Liters)	213	309	420	516
柜内温度 / Inner Temperature	1°C~8°C			
门数 / Doors	1	2	2	3
搁物架数量 / # of shelves	1	2	2	3
制冷剂 / Refrigerant	R 134a			
压缩机 / Compressor (Hp)	1/4	1/4	1/4	1/3
制冷方式 / Cooling Type	风冷式 (Fan cooling type)			
隔热方式 / Insulation Type	整体高密度发泡 (Polyurethane) / 环戊烷 (Cyclopentane) + 不含氟氯烃 (CFC Free)			
温度设定方式 / Temperature Control Type	数字控温 (Digital)			
电流 / Amps (A)	2.3	2.5	2.5	3.0
电源 / Voltage (V/Hz/Ph)	220V 50Hz 1Ph			
功率 / Power (W)	314	314	314	366
重量 / Weight (Kg)	75	89	100	120

M3-Series Salad Prep Table

TOP MOUNT [K.P.M3]

UNDER COUNTER [K.M3]

SALAD PREP [BUFFET:HOOD LID]

PIZZA TABLE

CHEF BASE

CMST-28

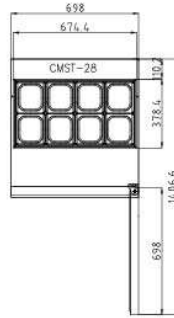

CMST-48

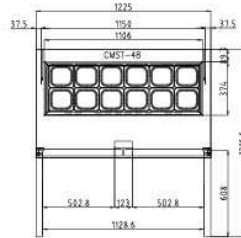

CMST-60

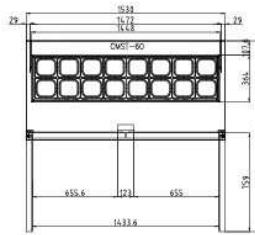

CMST-72

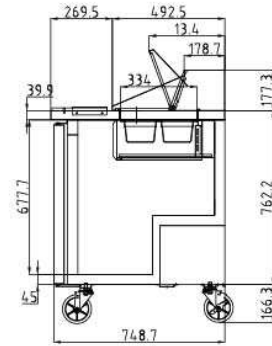
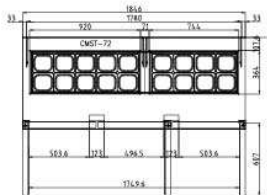

SIDE VIEW

型号 / MODEL	CMST-28	CMST-48	CMST-60	CMST-72
分类 / Classification	冷藏 (Refrigerator)			
外形尺寸 / Cabinet dimension (WxDxH mm)	698×762×1082	1225×762×1082	1530×762×1082	1846×762×1082
容量 / Capacity (Liters)	184	340	516	538
柜内温度 / Inner Temperature	1°C~8°C			
门数 / Doors	1	2	2	3
搁物架数量 / # of shelves	1	2	2	3
制冷剂 / Refrigerant	R 134a			
压缩机 / Compressor (Hp)	1/4	1/3	1/2	1/2
制冷方式 / Cooling Type	风冷式 (Fan cooling type)			
隔热方式 / Insulation Type	整体高密度发泡 (Polyurethane) / 环戊烷 (Cyclopentane) + 不含氟氯烃 (CFC Free)			
温度设定方式 / Temperature Control Type	数字控温 (Digital)			
电流 / Amps (A)	2.1	2.5	3.7	3.7
电源 / Voltage (V/Hz/Ph)	220V 50Hz 1Ph			
功率 / Power (W)	264	328	440	440
重量 / Weight (Kg)	90	110	150	170

M3-Series Mega Top Prep Table

CMST-28-12

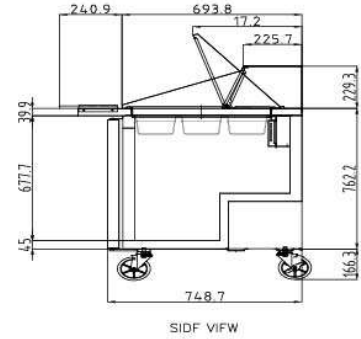
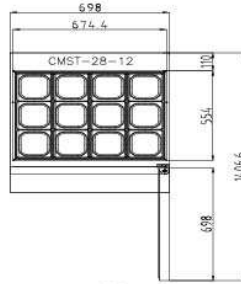

CMST-48-18

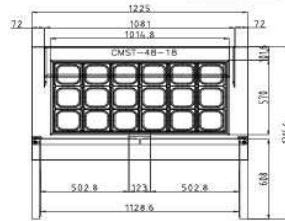

CMST-60-24

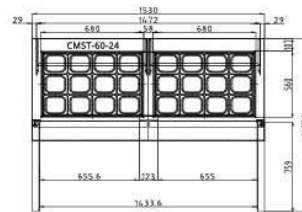

CMST-72-30

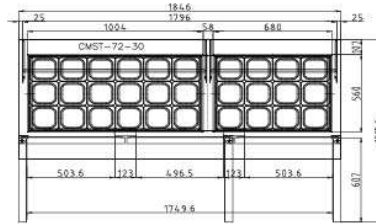

型号 / MODEL	CMST-28-12	CMST-48-18	CMST-60-24	CMST-72-30
分类 / Classification	冷藏 (Refrigerator)			
外形尺寸 / Cabinet dimension (WxDxH mm)	698×863×1134	1225×863×1134	1530×863×1134	1846×863×1134
容量 / Capacity (Liters)	224	416	526	640
柜内温度 / Inner Temperature	1°C~8°C			
门数 / Doors	1	2	2	3
搁物架数量 / # of shelves	1	2	2	3
制冷剂 / Refrigerant	R 134a			
压缩机 / Compressor (Hp)	1/4	1/3	1/2	1/2
制冷方式 / Cooling Type	风冷式 (Fan cooling type)			
隔热方式 / Insulation Type	整体高密度发泡 (Polyurethane) / 环戊烷 (Cyclopentane) + 不含氯氟烃 (CFC Free)			
温度设定方式 / Temperature Control Type	数字控温 (Digital)			
电流 / Amps (A)	3	4.7	4.7	5.8
电源 / Voltage (V/Hz/Ph)	220V 50Hz 1Ph			
功率 / Power (W)	314	366	366	440
重量 / Weight (Kg)	100	120	160	180

Pizza Table

TOP MOUNT [K.P.M.3]

CTPR-44SD

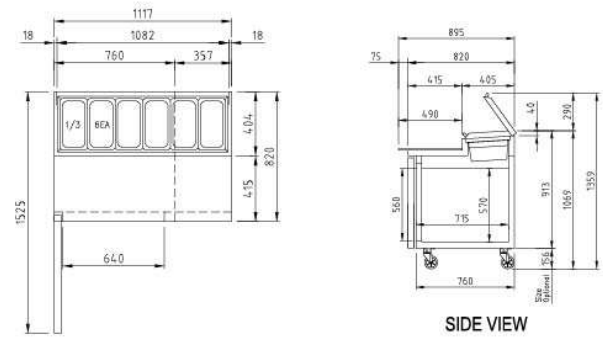

UNDER COUNTER [K.M.3]

CTPR-67SD

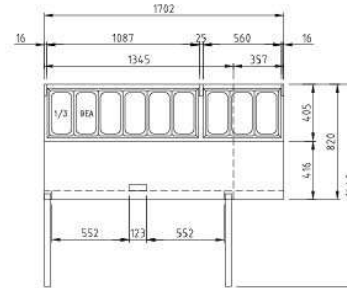

SALAD PREP [BUFFET HOOD LID]

CTPR-93SD

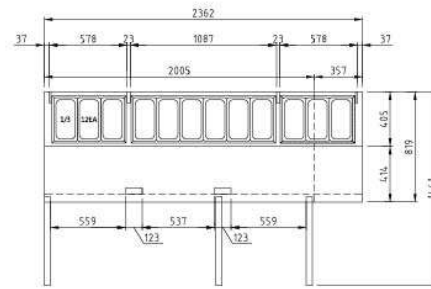

型号 / MODEL	CTPR-44SD	CTPR-67SD	CTPR-93SD
分类 / Classification	冷藏 (Refrigerator)		
外形尺寸 / Cabinet dimension (WxDxH mm)	1117x820x1069	1702x820x1069	2362x820x1069
容量 / Capacity (Liters)	396	566	878
柜内温度 / Inner Temperature	1°C~8°C		
门数 / Doors	1	2	3
搁物架数量 / # of shelves	2	4	6
制冷剂 / Refrigerant	R134a	R134a	R404A
压缩机 / Compressor (Hp)	1/3	7/8	3/4
制冷方式 / Cooling Type	风冷式 (Fan cooling type)		
隔热方式 / Insulation Type	整体高密度发泡 (Polyurethane) / 环戊烷 (Cyclopentane) + 不含氯氟烃 (CFC Free)		
温度设定方式 / Temperature Control Type	Thermostat		
电流 / Amps (A)	3.2	6.0	7.0
电源 / Voltage (V/Hz/Ph)	220V 50Hz 1Ph		
功率 / Power (W)	366	560	660
重量 / Weight (Kg)	140	187	262

PIZZA TABLE

CHEF BASE

TCBE-52SDR

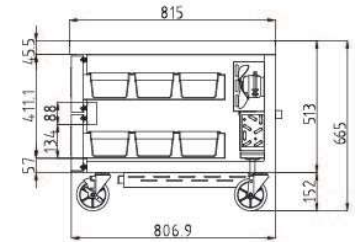
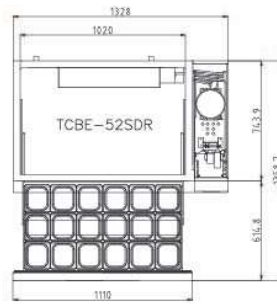

SIDE VIEW

TCBE-82SDR

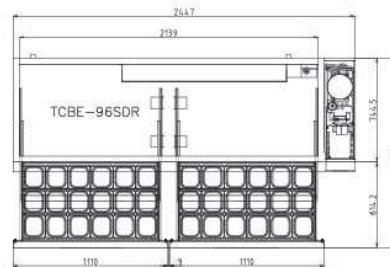
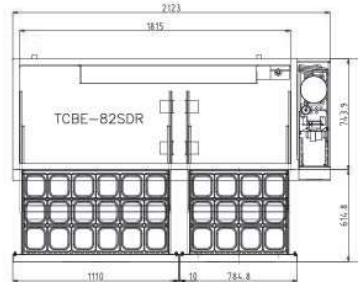

TCBE-96SDR



型号 / MODEL	TCBE-52SDR	TCBE-82SDR	TCBE-96SDR
分类 / Classification	冷藏 (Refrigerator)		
外形尺寸 / Cabinet dimension (WxDxH mm)	1328×815×673	2123×815×673	2447×815×673
容量 / Capacity (Liters)	311	538	651
柜内温度 / Inner Temperature	1°C~8°C		
门数 / Doors	0	0	0
搁物架数量 / # of shelves	0	0	0
制冷剂 / Refrigerant	R 134a		
压缩机 / Compressor (Hp)	1/4	1/4	1/4
制冷方式 / Cooling Type	风冷式 (Fan cooling type)		
隔热方式 / Insulation Type	整体高密度发泡 (Polyurethane) / 环戊烷 (Cyclopentane) + 不含氟氯烃 (CFC Free)		
温度设定方式 / Temperature Control Type	Thermostat		
电流 / Amps (A)	2.5	3.7	3.7
电源 / Voltage (V/Hz/Ph)	220V 50Hz 1Ph		
功率 / Power (W)	314	366	366
重量 / Weight (Kg)	110	186	219